

## Catalytic Stereoselective [2,3]-Rearrangement Reactions

Thomas H. West, Stéphanie S.M. Spoehrle, Kevin Kasten, James E Taylor, and Andrew D. Smith

*ACS Catal.*, **Just Accepted Manuscript** • DOI: 10.1021/acscatal.5b02070 • Publication Date (Web): 29 Oct 2015

Downloaded from <http://pubs.acs.org> on November 3, 2015

### Just Accepted

“Just Accepted” manuscripts have been peer-reviewed and accepted for publication. They are posted online prior to technical editing, formatting for publication and author proofing. The American Chemical Society provides “Just Accepted” as a free service to the research community to expedite the dissemination of scientific material as soon as possible after acceptance. “Just Accepted” manuscripts appear in full in PDF format accompanied by an HTML abstract. “Just Accepted” manuscripts have been fully peer reviewed, but should not be considered the official version of record. They are accessible to all readers and citable by the Digital Object Identifier (DOI®). “Just Accepted” is an optional service offered to authors. Therefore, the “Just Accepted” Web site may not include all articles that will be published in the journal. After a manuscript is technically edited and formatted, it will be removed from the “Just Accepted” Web site and published as an ASAP article. Note that technical editing may introduce minor changes to the manuscript text and/or graphics which could affect content, and all legal disclaimers and ethical guidelines that apply to the journal pertain. ACS cannot be held responsible for errors or consequences arising from the use of information contained in these “Just Accepted” manuscripts.

# Catalytic Stereoselective [2,3]-Rearrangement Reactions

Thomas H. West, Stéphanie S. M. Spoehrle, Kevin Kasten, James E. Taylor,

and Andrew D. Smith\*

*EaStCHEM, School of Chemistry, University of St Andrews, North Haugh, St Andrews, KY16*

*9ST, U.K.*

## ABSTRACT



Examples include [2,3]-rearrangement of:

- Onium ylides
- O-Propargylic oximes
- Sulfoxides, selenoxides, sulfimides, and *N*-oxides
- [2,3]-Wittig rearrangements

[2,3]-Sigmatropic rearrangement processes of allylic ylides or their equivalents can be applied to a variety of different substrates and generate products of wide interest / applicability to organic synthesis. This review describes the development and applications of stereoselective [2,3]-rearrangement reactions in which a sub-stoichiometric amount of a catalyst is used in either the formation of the reactive intermediate or the [2,3]-rearrangement step itself.

**Keywords:** Stereoselective catalysis, [2,3]-rearrangement, allylic oxonium ylides, allylic ammonium ylides, allylic sulfonium ylides, *O*-propargylic oximes, allylic sulfoxides, allylic *N*-oxides

## 1. INTRODUCTION

Stereoselective [2,3]-sigmatropic rearrangements have great utility in organic synthesis.<sup>1,2</sup> In particular, the ability to form carbon-carbon bonds with high diastereo- and enantioselectivity through well-defined and predictable transition states under often mild reaction conditions makes [2,3]-sigmatropic rearrangements attractive for the synthesis of complex targets. [2,3]-Sigmatropic processes can be broadly categorized into two main types: a) neutral rearrangements involving ylides and b) anionic rearrangements (Scheme 1). These reactions almost always involve at least one heteroatom and allow a number of different products containing various functional groups to be accessed.

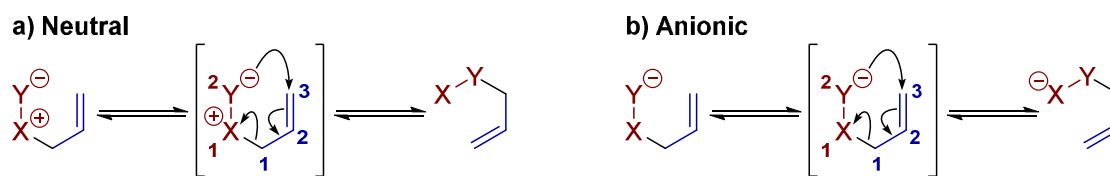

Scheme 1. General classifications of [2,3]-sigmatropic rearrangements

Many stereoselective [2,3]-rearrangements developed for organic synthesis utilize either existing stereocenters within the starting materials, chiral auxiliaries, or stoichiometric chiral ligands to control the configuration of the newly formed  $\sigma$ -bond. Advances in the development and applications of catalytic, stereoselective [2,3]-rearrangement reactions are less prevalent. This review surveys stereoselective [2,3]-rearrangement processes where a sub-stoichiometric amount of a catalyst is used in *either* the formation of the reactive ylide / anion *or* to promote the [2,3]-rearrangement itself (Scheme 2). The most widely explored processes within this remit are transition-metal catalyzed formations of allylic onium ylides from diazo compounds, followed by a facile *in situ* [2,3]-rearrangement (Section 2). More recently, alternative methods for the catalytic [2,3]-rearrangement of allylic ammonium ylides derived from quaternary ammonium salts have been developed (Section 3). The transition-metal promoted rearrangement of *O*-propargylic oximes generates highly reactive

1  
2  
3 allenyl nitrene intermediates that can participate in a number of different reaction cascades  
4  
5 (Scheme 4). Catalytic variants of commonly used [2,3]-rearrangements of allylic sulfoxides  
6  
7 (Mislow-Evans), selenoxides (Riley oxidation), sulfimides, and *N*-oxides (Meisenheimer)  
8  
9 have also been explored (Section 5). Finally, a limited number of catalytic, stereoselective  
10  
11 anionic [2,3]-Wittig rearrangements have been reported (Section 6).  
12  
13

14  
15 **2. Onium ylides from metal carbenoids**

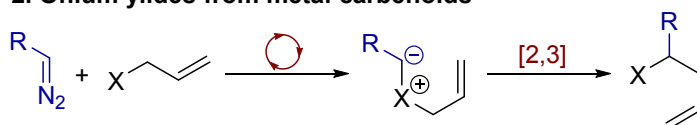

X = R<sub>2</sub>N, RO, RS, halogen

3. Ammonium ylides from quaternary ammonium salts

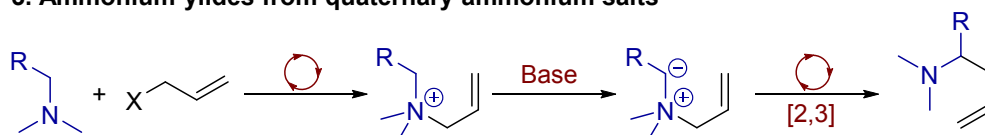

4. O-Propargylic oximes

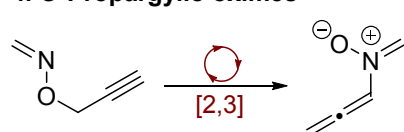

5. Sulfoxides, selenoxides, sulfimides, and *N*-oxides

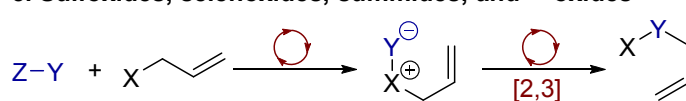

X = RS, RSe, R<sub>2</sub>N

Y = O, RN

6. [2,3]-Wittig rearrangements

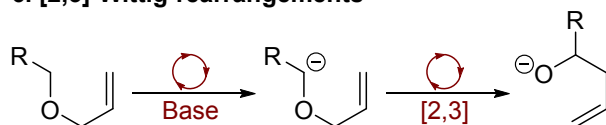

Scheme 2. Overview of catalytic [2,3]-rearrangements discussed

## 1.1 General mechanism and stereochemical control

[2,3]-Sigmatropic rearrangements are symmetry allowed concerted processes that proceed through a five-membered, six-electron transition state with an envelope conformation. The presence of a heteroatom within the reaction framework lowers the energy of these processes and can provide additional stabilization of the transition state through resonance contributions. Generally, [2,3]-rearrangements of allylic ammonium ylides are favorable processes, but competing [1,2]- or [1,4]-rearrangements (where possible) are observed in some cases.

Stereocontrolled [2,3]-rearrangement processes can generate up to two new stereogenic centers around the newly formed  $\sigma$ -bond and allow (*E*)- or (*Z*)-selectivity within the new  $\pi$ -bond. The greater conformational flexibility of five-membered transition states compared with six-membered transition states of [3,3]-sigmatropic rearrangements make them more susceptible to substituent effects and complete stereocontrol can be difficult to attain.<sup>3</sup>

The observed diastereoselectivity of [2,3]-rearrangement of generic substrates such as (*E*)-**1** is dependent on the relative energies of the *exo*-**2** and *endo*-**3** transition states as outlined by Houk and Marshall for the [2,3]-Wittig rearrangement (Scheme 3a).<sup>4</sup> The stereochemical preference for a given process is dependent on both steric and stereoelectronic properties of the two-substituents ( $R^1$  and  $R^2$ ) as well as the heteroatom present. [2,3]-Sigmatropic rearrangements are often stereospecific, with (*E*)-**1** and (*Z*)-**6** isomers leading to the formation of the opposite product diastereoisomers (Scheme 3b). For example, rearrangement of (*E*)-**1** through *exo*-type transition state **2** leads to the formation of ( $\pm$ )-*anti*-**4**, whereas rearrangement of the corresponding (*Z*)-**6** through *exo*-type transition **7** state gives ( $\pm$ )-*syn*-**5**.

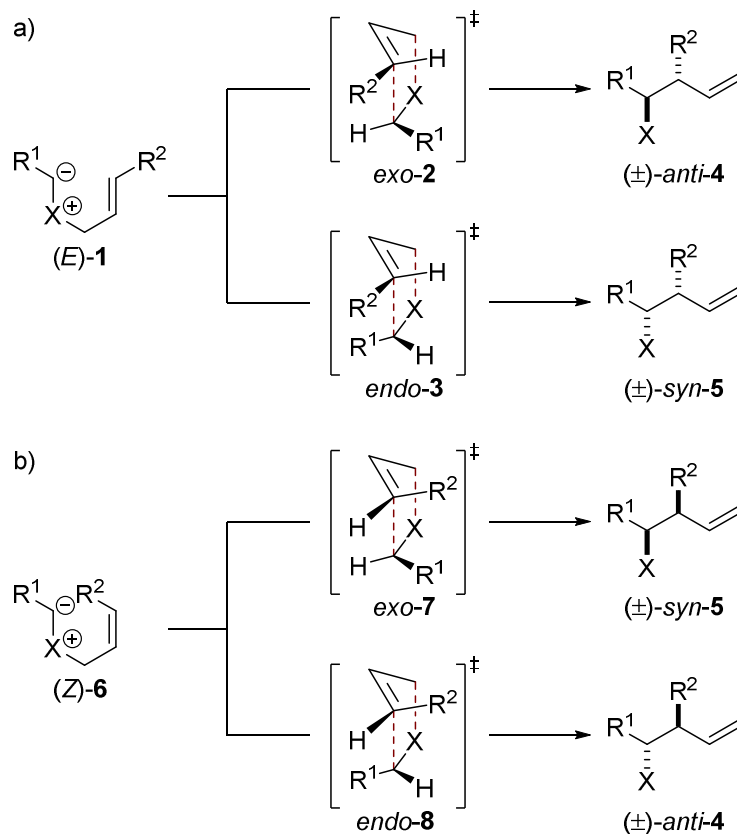

**Scheme 3.** Generic pre-transition state assemblies for diastereoselective [2,3]-rearrangements

33  
34  
35  
36  
37  
38  
39  
40  
41  
42

The geometry of the newly formed  $\pi$ -bond after [2,3]-rearrangement is also subject to stereocontrol by the substituents. As a result, the (*E*)-alkene geometry is often favored over the corresponding (*Z*)-alkene due to minimization of allylic 1,3-strain in transition state **10** compared with **11** (Scheme 4).<sup>3,5</sup>

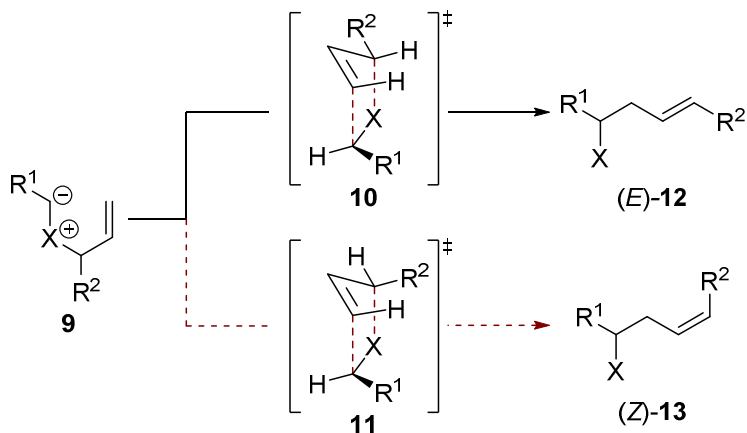

**Scheme 4.** Control of (*E*)/(*Z*)-alkene geometry in [2,3]-rearrangements

1  
2  
3 While these general stereochemical considerations can often be used to account for the  
4  
5 observed diastereoselectivity, the precise origin of any enantioselectivity is poorly understood  
6  
7 in many cases. There are relatively few detailed mechanistic studies regarding catalytic  
8  
9 stereoselective [2,3]-rearrangements as these processes are often highly complex and difficult  
10  
11 to probe experimentally and computationally.  
12  
13

## 14 15 16 **2. METAL-CATALYZED ONIUM YLIDE FORMATION AND [2,3]-** 17 18 **REARRANGEMENTS VIA METAL CARBENOIDS** 19

20  
21 The use of diazo compounds as allylic onium ylide precursors in [2,3]-rearrangements has  
22  
23 been widely studied.<sup>6</sup> The metal-catalyzed decomposition of diazo compounds proceeds  
24  
25 readily to form metal carbenoids with concomitant loss of nitrogen. A wide range of  
26  
27 transition-metal complexes can be used for this purpose with catalysts based upon rhodium  
28  
29 and copper by far the most common, although iron, cobalt, ruthenium, silver, platinum, and  
30  
31 gold-based complexes have been used. The metal carbenoid species can react *in situ* with  
32  
33 allylic ethers, amines, sulfides, and allyl halides to form the corresponding allylic onium  
34  
35 ylides that can undergo the desired [2,3]-rearrangement. (Scheme 5) However, metal  
36  
37 carbenoids are often highly reactive intermediates that can participate in a variety of  
38  
39 competing processes including cyclopropanation reactions alongside C-H, O-H and Si-H  
40  
41 insertions. It is therefore often necessary to tune the metal-ligand combination used in order  
42  
43 to bias the desired chemoselectivity for [2,3]-rearrangement over any competing processes.  
44  
45  
46  
47  
48  
49  
50  
51  
52  
53  
54  
55  
56  
57  
58  
59  
60

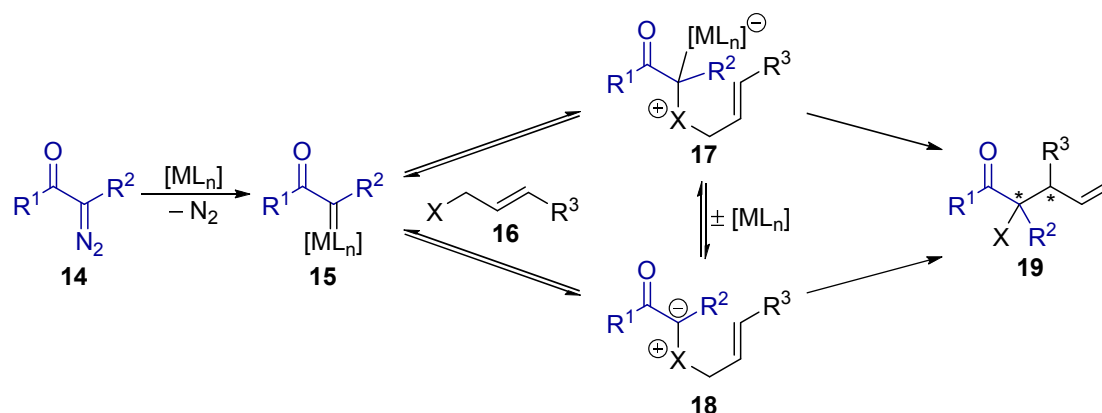

**Scheme 5.** Onium ylides generated from metal carbenoids **15** and subsequent [2,3]-rearrangement. X = R<sub>2</sub>N, RO, RS, RSe, Br, or I

There has been extensive work on developing diastereo- and/or enantioselective onium ylide [2,3]-rearrangements originating from the catalytic decomposition of diazo compounds. A successful strategy in diastereoselective processes makes use of achiral transition-metal complexes reacting with diazo compounds bearing chiral auxiliaries and/or existing stereogenic centers. The development of [2,3]-rearrangements *via* metal carbenoids in which control of the product configuration is derived catalytically from a chiral metal complex has been more challenging. One of the key factors in determining the success of an enantioselective variant is the degree of association between the chiral metal complex and the ylide during the [2,3]-rearrangement step.<sup>6b</sup> If the metal complex dissociates prior to rearrangement then any enantiocontrol must arise from a configurationally restricted ylide, otherwise a racemic product will be observed. The number of potential reaction pathways and complexity of these processes makes detailed elucidation of the reaction mechanism challenging. As a result, many catalytic asymmetric [2,3]-rearrangements from metal carbenoid species are optimized through traditional ligand-screening approaches.



## 2.1 Oxonium ylides.

**2.1.1 Intermolecular oxonium ylide formation and [2,3]-rearrangement.** The [2,3]-rearrangement of allylic oxonium ylides generated from the intermolecular reaction between metal carbenoids and allyl ethers is challenging, with side reactions including cyclopropanation and [1,2]-insertion reactions potentially problematic. Doyle and co-workers were the first to report the diastereoselective [2,3]-rearrangement of oxonium ylides from the reaction of catalytically generated rhodium carbenoids and allylic ethers.<sup>7</sup> For example, the dropwise addition of ethyl diazoacetate **20** to a solution of Rh<sub>2</sub>(OAc)<sub>4</sub> (1 mol%) and allylic ether **21** led to the selective formation of [2,3]-rearrangement product **22** in 92% yield and 83:17 dr (*syn:anti*), although competitive cyclopropanation to generate **23** was also observed (Scheme 6a). The reaction was applicable to both diazoacetates and diazoacetophenones, alongside a small range of substituted allylic ethers, with [2,3]-rearrangement favored over cyclopropanation in all cases. Doyle subsequently reported a highly enantioselective version of this process utilizing a rhodium complex bearing enantiomerically pure oxazolidin-2-one ligand **24** (Scheme 6b).<sup>8</sup> Under these conditions [2,3]-rearrangement is again favored over cyclopropanation, with the major product **25** isolated in 36% yield, 85:15 dr (*anti:syn*), and an impressive 98% ee. In this case the major diastereoisomer formed is opposite to that preferentially formed using the achiral rhodium catalyst. The catalyst-dependent diastereoselectivity observed suggests a metal-associated ylide is involved in the product forming step of these reactions.

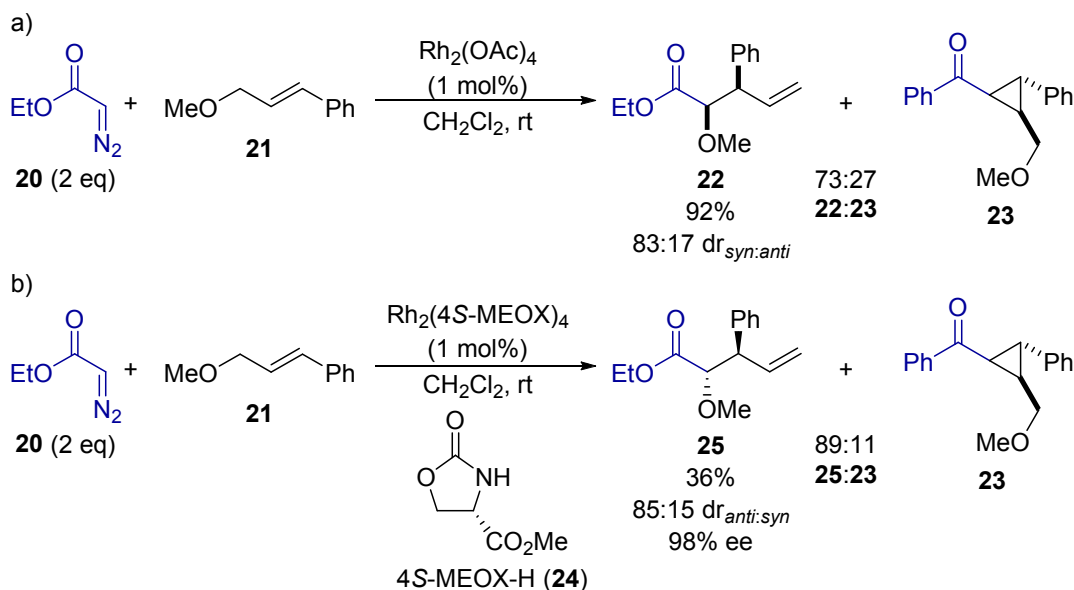

**Scheme 6.** a) Diastereoselective intermolecular oxonium ylide formation and [2,3]-rearrangement. b) Enantioselective version using oxazolidin-2-one **24** as a ligand

26  
27  
28  
29  
30  
31  
32  
33  
34  
35  
36  
37

Quinn and co-workers reported the copper-catalyzed reaction of diazoacetate **26** with  $\text{C}_2$ -symmetric vinyl epoxide **27** to give the ring-expanded *cis*-dihydropyran **28** in good yield as a single diastereoisomer (Scheme 7).<sup>9</sup> However, the process was limited to symmetric epoxide **27**, with other substituted vinyl epoxides giving low yields and poor selectivity towards the desired [2,3]-rearrangement pathway.

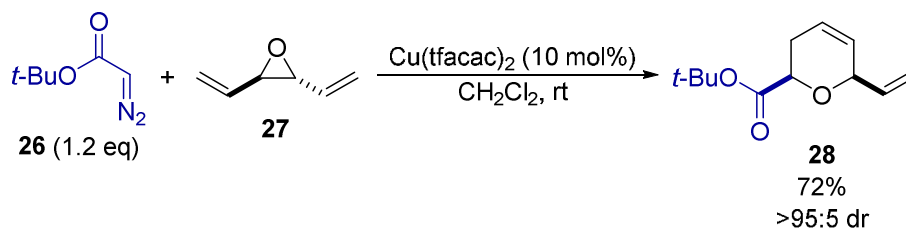

**Scheme 7.** Copper-catalyzed ring-expansion of vinyl epoxide **27**

46  
47  
48  
49  
50  
51  
52  
53  
54  
55  
56  
57  
58  
59  
60

Njardarson and co-workers showed that copper carbenoids generated from the decomposition of diazoacetophenone **29** undergo oxonium ylide formation and [2,3]-rearrangement with a variety of substituted allylic ethers.<sup>10</sup> For example, reaction with symmetrical allylic ether **30** forms product **31** in good yield and high diastereoselectivity, with subsequent ring-closing metathesis of **31** using Grubbs II catalyst giving pyran **32** in high yield (Scheme 8a). The

reaction of **29** with unsymmetrical allylic ether (*E*)-**33** followed by deprotection of the [2,3]-rearrangement product **34** with  $\text{BF}_3 \cdot \text{Et}_2\text{O}$  gave  $\alpha$ -hydroxy ketone **35** with high levels of diastereoselectivity (Scheme 8b). This process is stereospecific, with (*Z*)-allylic ether **36** reacting to give the corresponding *syn*-product **37** with reasonable levels of diastereoselectivity (Scheme 8c).

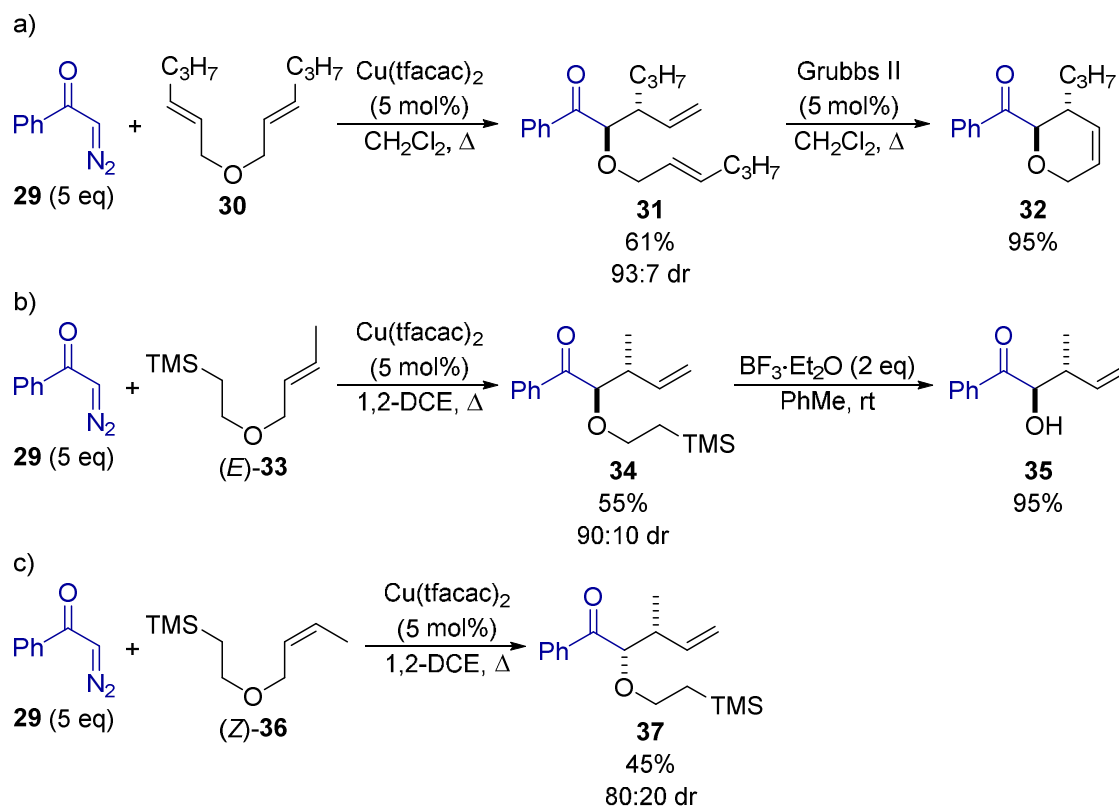

**Scheme 8.** Diastereoselective reaction of diazoacetophenone **29** with functionalized allylic ethers

In 2009, Davies and co-workers reported a highly enantioselective oxonium ylide generation-[2,3]-rearrangement of racemic allylic alcohols with donor-acceptor diazo compounds using a chiral rhodium catalyst.<sup>11</sup> The substitution pattern of the allylic alcohol is key to determining the chemoselectivity of the reaction. For example, reacting diazo compound **38** with primary allylic alcohol **39** exclusively formed O-H insertion product **43**, whereas the reaction with secondary allylic alcohol **40** selectively gave [2,3]-rearrangement product **42** in good yield and excellent enantioselectivity (Scheme 9a). This trend was general for a range of substrates,

with various substituted secondary and tertiary allylic alcohols reacting to give [2,3]-rearrangement products with high levels of chemo- and enantioselectivity. The enantioselectivity of the process is derived purely from the chiral ligand **41** as racemic, (*R*)- and (*S*)-allylic alcohol **40** all react with methyl 2-diazo-2-phenyl acetate **44** to give the same absolute configuration of the corresponding [2,3]-rearrangement product **45** (Scheme 9b).

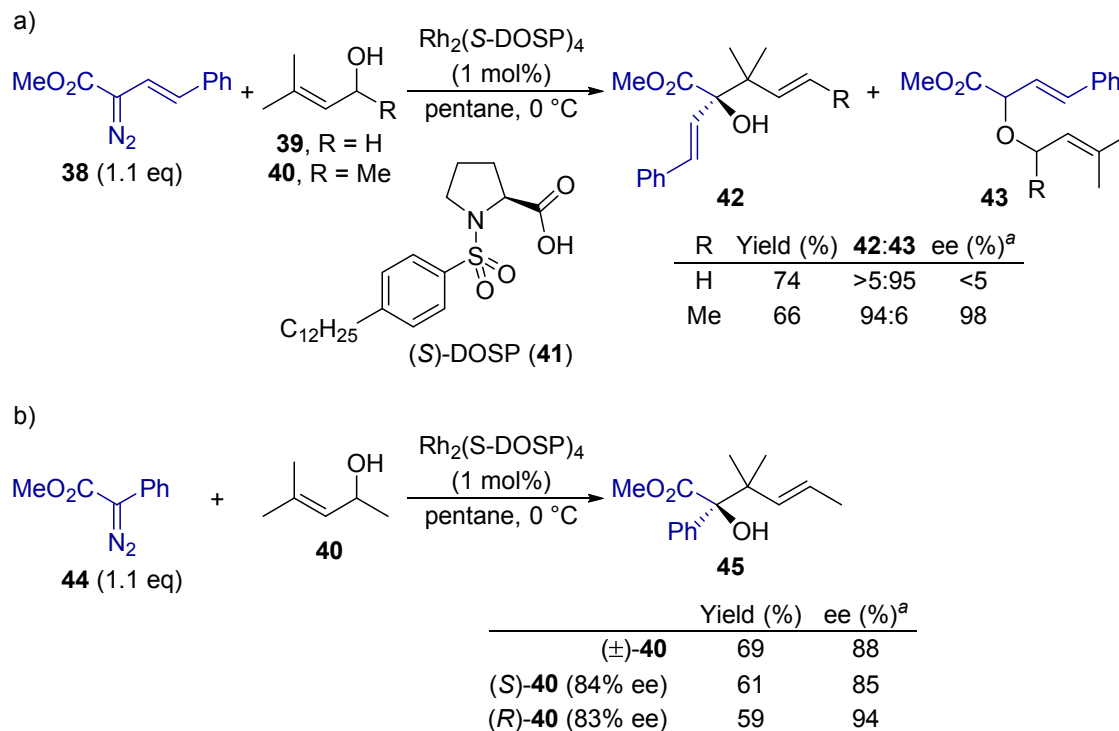

**Scheme 9.** Enantioselective [2,3]-rearrangement reactions using racemic allylic alcohols. <sup>a</sup>ee of major product

This methodology was extended to the enantioselective synthesis of products containing two vicinal stereocenters.<sup>12</sup> The reaction is stereospecific with respect to the geometry of the allylic alcohol, with (*E*)-**46** reacting with diazo compound **38** to give product **47** and (*Z*)-**48** reacting under the same conditions to give the opposite diastereoisomer **49** (Scheme 10). The matched/mismatched effect between the allylic alcohol configuration and chiral catalyst was much more significant for (*Z*)-allylic alcohol **48** with the reaction using (*S*)-DOSP **41** as the ligand leading to reduced yields and diastereoselectivity. Through judicious choice of alcohol configuration, alkene geometry and chiral ligand used, all four possible stereoisomers of the

[2,3]-rearrangement products were accessible. The scope of the reaction has been fully explored, with a number of  $\alpha$ -aryl and  $\alpha$ -alkenyl diazoacetates reacting with a wide variety of substituted allylic alcohols to give the rearranged products in uniformly high yields and excellent diastereo- and enantioselectivity. The same catalytic system has been utilized in the reaction of  $\alpha$ -aryl and  $\alpha$ -alkenyl diazoacetates with tertiary propargylic alcohols to form substituted allenes in high enantioselectivity.<sup>13</sup> When racemic tertiary propargylic alcohols were used, kinetic resolution was observed with the allene rearrangement products formed in good dr and high ee and the unreacted propargylic alcohols recovered enantioenriched. A silica-supported version of  $\text{Rh}_2(\text{S-DOSP})_4$  can also be used for the catalytic oxonium ylide formation and [2,3]-rearrangement reactions using both allylic alcohols and propargylic alcohols, forming the corresponding products in good yields with enantioselectivity comparable with those obtained in the homogeneous reactions.<sup>14</sup>

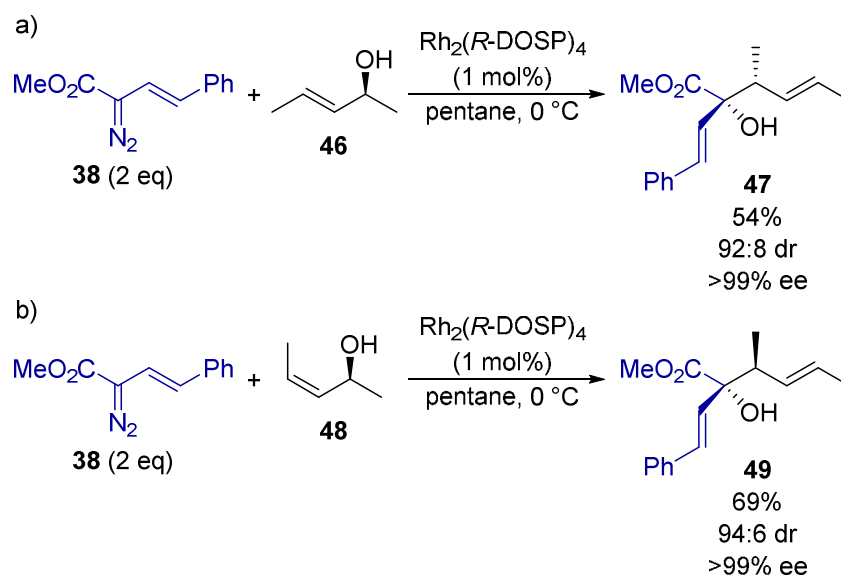

**Scheme 10.** Stereospecific [2,3]-rearrangement of allylic alcohols

Davies and co-workers have applied their methodology to the synthesis of highly functionalized cyclopentanes through a complex domino reaction sequence.<sup>15</sup> As previously, reacting  $\alpha$ -alkenyl diazo compounds such as **38** with allylic alcohol **46** in the presence of a

1  
2  
3 chiral rhodium catalyst promotes oxonium ylide formation followed by enantioselective  
4 [2,3]-rearrangement. Heating product **47** in a sealed-tube promotes an oxy-Cope  
5 rearrangement followed by tautomerization, and an intramolecular ene cyclization to form  
6 substituted cyclopentane **51** containing four contiguous stereocenters in high diastereo- and  
7 enantioselectivity (Scheme 11a). Although racemic allylic alcohols can be utilized in this  
8 reaction, higher enantioselectivity was obtained using enantiomerically pure allylic alcohols  
9 and a matched chiral rhodium catalyst.<sup>15b</sup> The process was applicable to a variety of  
10 substituted allylic alcohols, forming functionalized cyclopentanes in high yields and excellent  
11 diastereo- and enantioselectivity in all cases. Introducing a C(3) methyl substituent onto the  
12 allylic alcohol alters the reaction pathway, with a type II-ene cyclization favored to form  
13 cyclohexane products containing an exocyclic alkene substituent and four stereogenic  
14 centres.<sup>16</sup> For example, the rhodium catalyzed reaction of **38** with allylic alcohol **52** followed  
15 by heating in heptane results in the formation of substituted cyclohexane **53** in 67% yield as a  
16 single diastereoisomer in 99% ee (Scheme 11b). This domino reaction sequence was  
17 applicable to a range of  $\alpha$ -alkenyl diazo compounds and substituted allylic alcohols, forming  
18 the products in excellent diastereo- and enantioselectivity. Cyclic allylic alcohols, including a  
19 monoterpenoid derived substrate, could also be utilized to generate a series of structurally  
20 complex fused-bicyclic products with high diastereoselectivity.  
21  
22  
23  
24  
25  
26  
27  
28  
29  
30  
31  
32  
33  
34  
35  
36  
37  
38  
39  
40  
41  
42  
43  
44  
45  
46  
47  
48  
49  
50  
51  
52  
53  
54  
55  
56  
57  
58  
59  
60

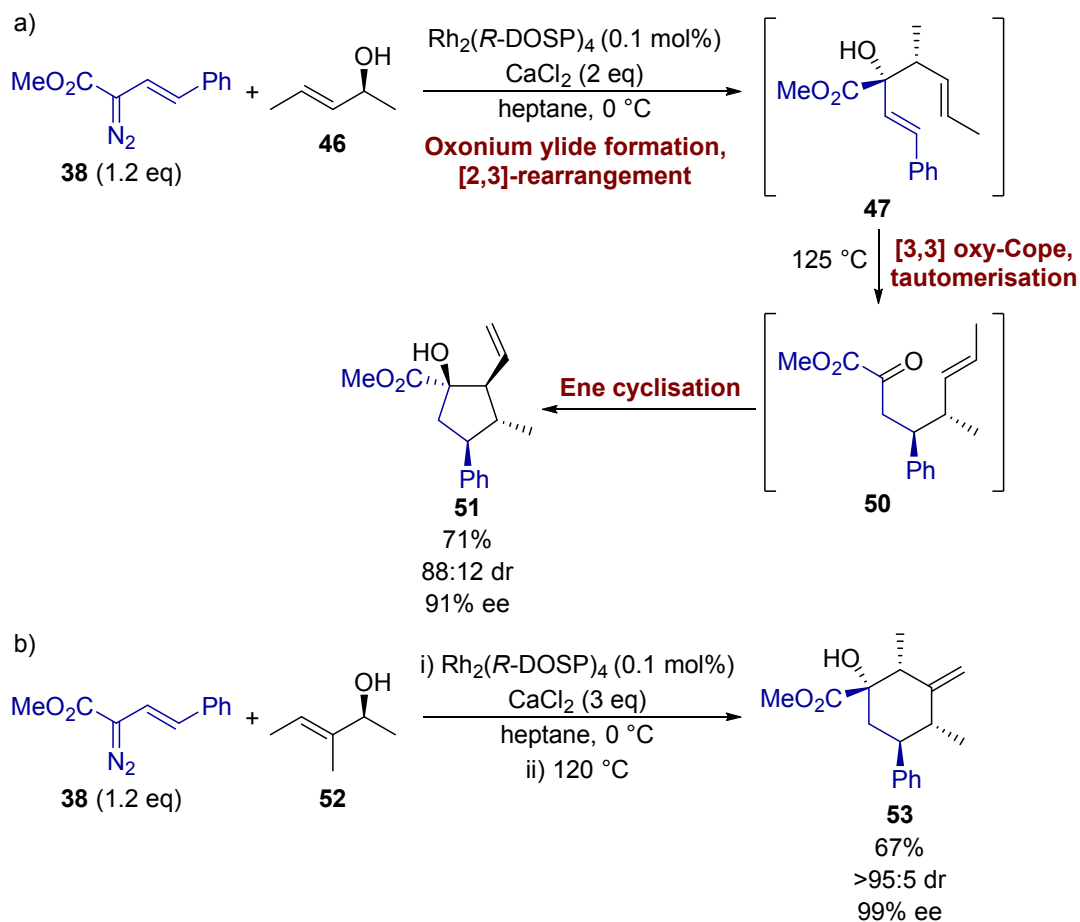

**Scheme 11.** Domino reaction sequence for the synthesis of a) cyclopentanes and b) cyclohexanes

**2.1.2 Diastereoselective intramolecular oxonium ylide formation and [2,3]-rearrangement.** The intramolecular generation and [2,3]-rearrangement of oxonium ylides from diazo compounds offers an efficient and potentially stereoselective route towards a variety of highly functionalized oxocyclic products. The synthetic utility of these [2,3]-rearrangement products has been widely demonstrated through the synthesis of a variety of complex natural products.

In 1986 Johnson<sup>17</sup> and Pirrung<sup>18</sup> independently reported the first examples of diastereoselective catalytic generation and [2,3]-rearrangement of oxonium ylides. For example, treating allyloxy-substituted diazoketone **54** with  $\text{Rh}_2(\text{OAc})_4$  (1 mol%) generates oxonium ylide **55** *in situ*, which undergoes intramolecular [2,3]-rearrangement to form

furanone **56** in 65% yield and excellent 93:7 dr (*anti:syn*) (Scheme 12). Importantly, this class of allyloxy diazoketones exhibited excellent chemoselectivity for [2,3]-rearrangement over potential [1,2]-rearrangement under the reaction conditions.

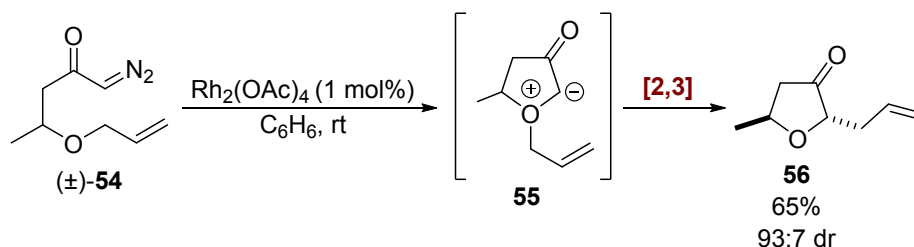

**Scheme 12.** Rearrangement of oxonium ylide **55** generated from alkoxy-substituted diazoketone **54**

Pirrung and co-workers subsequently utilized the catalytic oxonium ylide generation and [2,3]-rearrangement methodology in the first enantioselective total synthesis of the antifungal agent (+)-griseofulvin **59**.<sup>19</sup> The key step within this sequence involves the diastereoselective [2,3]-rearrangement of the oxonium ylide generated from enantiomerically pure diazoketone **57** using  $\text{Rh}_2(\text{piv})_4$  (5 mol%) to form advanced intermediate **58** in 62% yield as a single stereoisomer (Scheme 13). The reaction is also completely chemoselective, with no products from potential competing *o*-methoxy ylide formation or [1,2]-rearrangement observed.

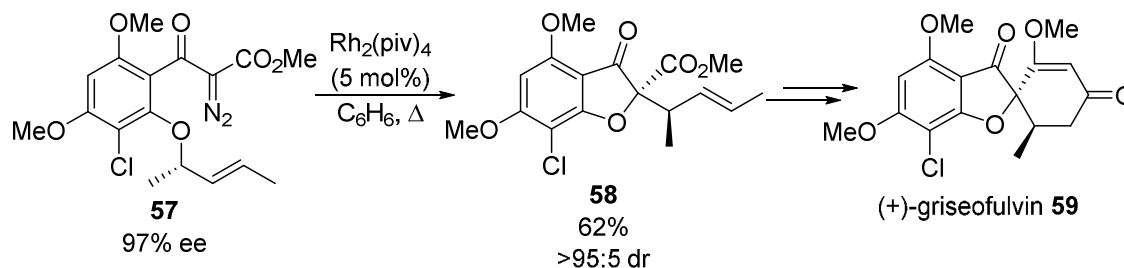

**Scheme 13.** Enantioselective synthesis of (+)-griseofulvin **59**

The concept of catalytic oxonium-ylide formation and [2,3]-rearrangement was further explored by Clark in 1992 with the demonstration of an intramolecular  $\text{Cu}(\text{acac})_2$  catalyzed tandem carbenoid insertion and [2,3]-rearrangement process to form *anti*-tetrahydrofuran-3-



ones in good yields with excellent levels of diastereoselectivity (Scheme 14).<sup>20</sup> In this case catalytic  $\text{Rh}_2(\text{OAc})_4$  was ineffective, giving the products in modest yields with lower levels of diastereoselectivity.

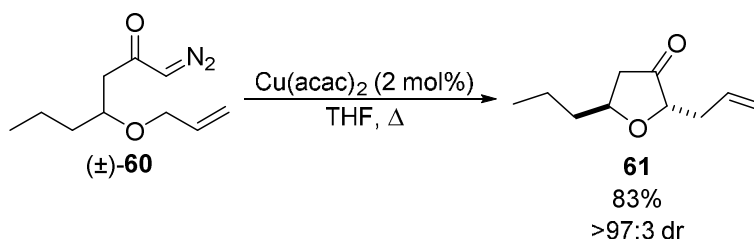

**Scheme 14.** Copper-catalyzed generation and [2,3]-rearrangement of oxonium ylides

Clark and co-workers have subsequently used this synthetic procedure as a key step towards the total synthesis of a wide variety of natural products. For example, the divergent synthesis of three of the family of amphidinolide macrolide natural products utilizes the copper-catalyzed decomposition of diazoketone **63** and diastereoselective rearrangement of the resulting oxonium ylide as a key step.<sup>21</sup> Commercially available alcohol **62** is readily converted in three steps into diazoketone **63**, which upon treatment with  $\text{Cu}(\text{acac})_2$  (10 mol%) in THF at reflux undergoes a diastereoselective oxonium ylide formation and [2,3]-rearrangement to give dihydrofuranone **64** in 91% yield as a single diastereoisomer (Scheme 15a). Dihydrofuranone **64** serves as a common intermediate in the divergent total synthesis of amphidinolides T1, T3 and T4 (**65-67**) (Scheme 15b). Analogous methodology has also been used as the key step in the preparation of fragments of large natural products including the amphidinolides,<sup>22</sup> gambieric acid A,<sup>23</sup> and cinatrin C<sub>1</sub>.<sup>24</sup>

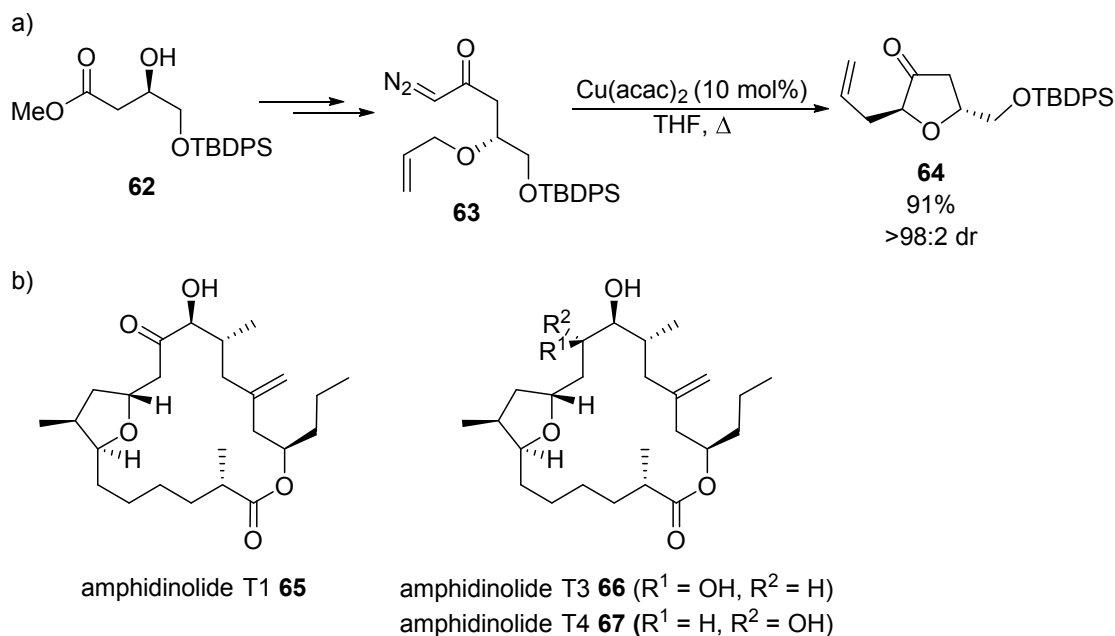

**Scheme 15.** Divergent total syntheses of amphidinolides T1, T3, and T4 (**65-67**)

Mechanistically, Clark found that the equilibrium between metal-bound and free-ylides in a non-stereoselective intramolecular oxonium ylide [2,3]-rearrangement process is highly dependent on both the catalyst and substrate.<sup>25</sup> For example, treating <sup>13</sup>C labelled  $\alpha$ -diazo  $\beta$ -keto ester **68** with various transition-metal catalysts resulted in a variable mixture of [2,3]-rearrangement product **69** and formal [1,2]-rearrangement product **70** (Scheme 16). The catalyst-dependent reaction outcome suggests this reaction may proceed *via* either a metal-bound ylide species or alternative non-ylide pathways to give the formally rearranged products.

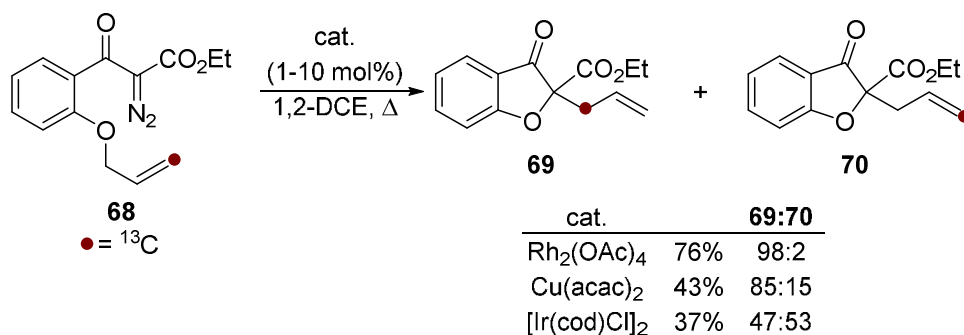

**Scheme 16.** Isotopic substitution suggests metal-bound non-ylide mechanistic pathways

In 2008, Hodgson and co-workers reported a tandem cross-metathesis-oxonium ylide formation [2,3]-rearrangement protocol for the diastereoselective synthesis of dihydrofuranones, which was applied to the synthesis of anti-HIV agent hyperolactone C.<sup>26</sup> Diazoketone **71** was treated with Grubbs II catalyst and methacrolein **72** to form **73** *in situ*, catalytic  $\text{Rh}_2(\text{OAc})_4$  (4 mol%) was then added to promote diastereoselective oxonium ylide formation and [2,3]-rearrangement (Scheme 17). The resulting dihydrofuranone **74** was immediately reduced with  $\text{NaBH}_3\text{CN}$  to form fused hemiketal **75** in 26% yield over the three-steps with good diastereocontrol. A further two steps finished the synthesis of the spirocyclic hyperolactone C **76**. Hodgson subsequently reported an enantioselective synthesis of (-)-hyperolactone C **76** starting from enantiomerically pure diazoketone **71**.<sup>27</sup>

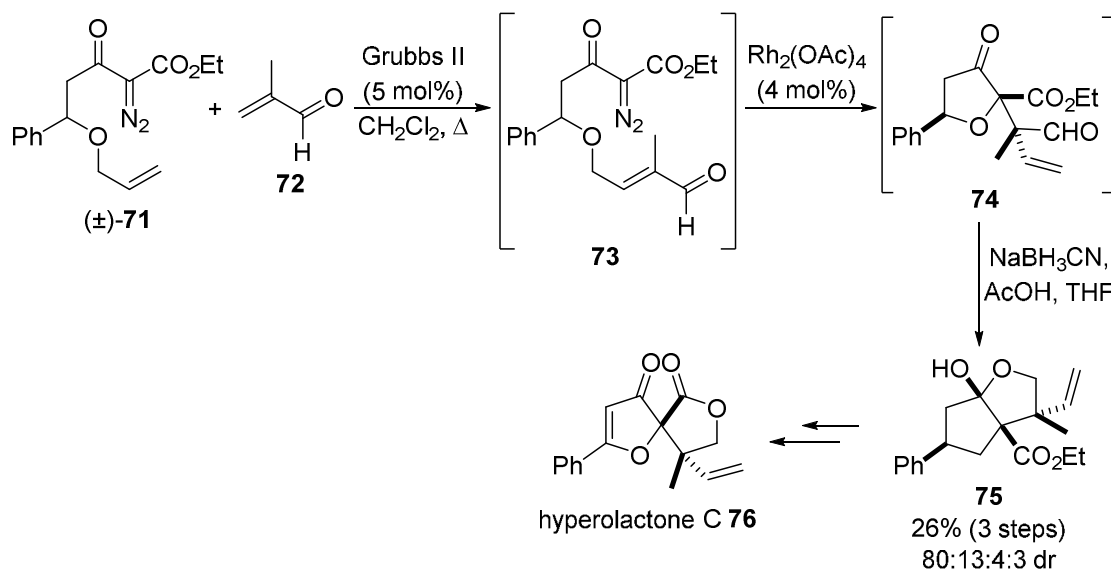

Scheme 17. Diastereoselective synthesis of (±)-hyperolactone C **76**

In 2014 Hodgson reported a new route to a small number of hyperolactone C analogues through intramolecular oxonium ylide formation and [2,3]-rearrangement of diazoacetals. For example, treating diazoacetal **77** with  $\text{Rh}_2(\text{tfa})_4$  (1 mol%) forms bicyclic acetal **78** in 43% yield as a single diastereoisomer (Scheme 18).<sup>28</sup> Acid-catalyzed elimination of acetal **78** and subsequent lactonization led to the formation of spirofuranone **79** in high yield.

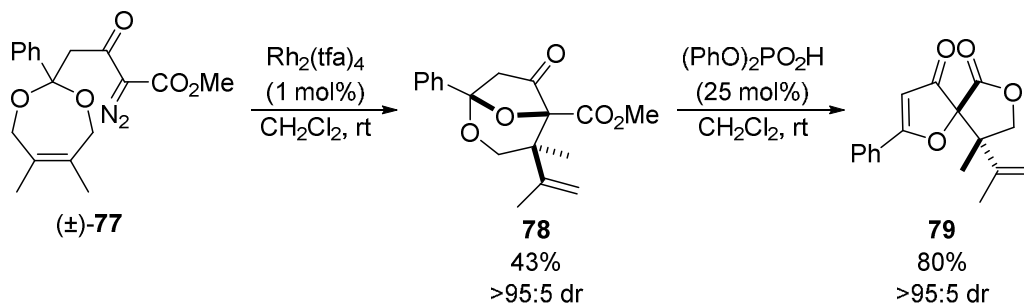

**Scheme 18.** Synthesis of (±)-hyperolactone C analogue from diazoacetal **77**

16  
17  
18  
19  
20  
21  
22  
23  
24  
25  
26  
27  
28  
29

Clark and co-workers have extended this methodology to the synthesis of tetrahydropyran-3-ones. Building on an earlier diastereoselective synthesis,<sup>29</sup> the enantioselective synthesis of the fungal metabolite (+)-decarestrictine L **83** was reported starting from ethyl (*R*)-3-hydroxybutyrate **80**.<sup>30</sup> Treatment of enantiomerically pure diazoketone **81** with  $\text{Cu}(\text{tfacac})_2$  (2 mol%) gave tetrahydropyran-3-one **82** in 60% yield and 91:9 dr (Scheme 19). Four further steps converted **82** into (+)-decarestrictine L **83** in an overall 9% yield over ten steps.

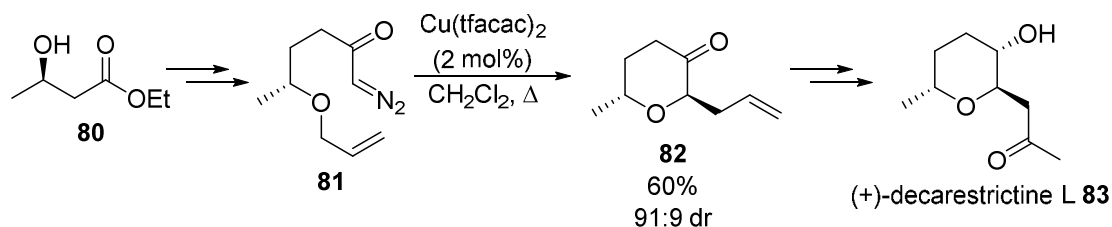

**Scheme 19.** Enantioselective synthesis of (+)-decarestrictine L **83**. tfacac = trifluoroacetylacetonate

41  
42  
43  
44  
45  
46  
47  
48  
49  
50  
51  
52  
53  
54  
55  
56  
57  
58  
59  
60

A similar approach has been employed to synthesize a large number of structurally complex diterpene marine natural products through formation of bicyclic allylic oxonium ylides followed by diastereoselective [2,3]-rearrangement. For example, the first total synthesis of (±)-vigulariol **87**, a member of the Cladiellin family possessing *in vitro* cytotoxic activity against human lung cancer cells, utilized the copper-catalyzed decomposition of diazo intermediate **84** and [2,3]-rearrangement of the resulting oxonium ylide (Scheme 20).<sup>31</sup> The bicyclic products (*Z*)-**85** and (*E*)-**86** were formed in 96% yield as an 83:17 mixture, with the undesired (*E*)-**86** subsequently isomerized into (*Z*)-**85** using AIBN and ethanethiol. Related

strategies using bicyclic oxonium ylides generated in the same way have been utilized in the synthesis of a number of other natural products including other members of the Cladiellin family of diterpenes,<sup>32</sup> sclerophytin F,<sup>33</sup> the tricyclic core of labiatin A and Australin A<sup>34</sup>, and neoliacinic acid.

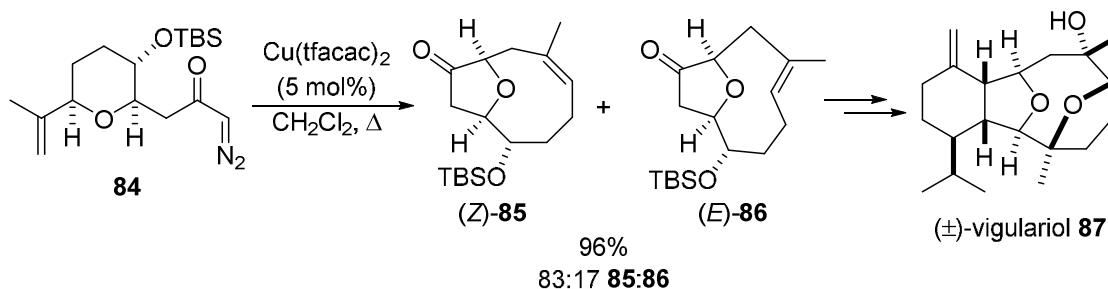

**Scheme 20.** Synthesis of (±)-vigulariol **87**

In 2001 West and co-workers reported a diastereoselective iterative synthesis of polypyran scaffolds, which are common cores in polyether marine natural products.<sup>35</sup> Treatment of diazoketone **88** with  $\text{Cu}(\text{tfacac})_2$  (5 mol%) induced a diastereoselective oxonium-ylide formation-[2,3]-rearrangement process to give bicyclic ether **89** in good yield and high diastereoselectivity (Scheme 21). Further manipulation of **89** into diazoketone **90** set up a second copper-catalyzed [2,3]-rearrangement step to form polypyran fragment **91** in 80% yield as a single diastereoisomer.

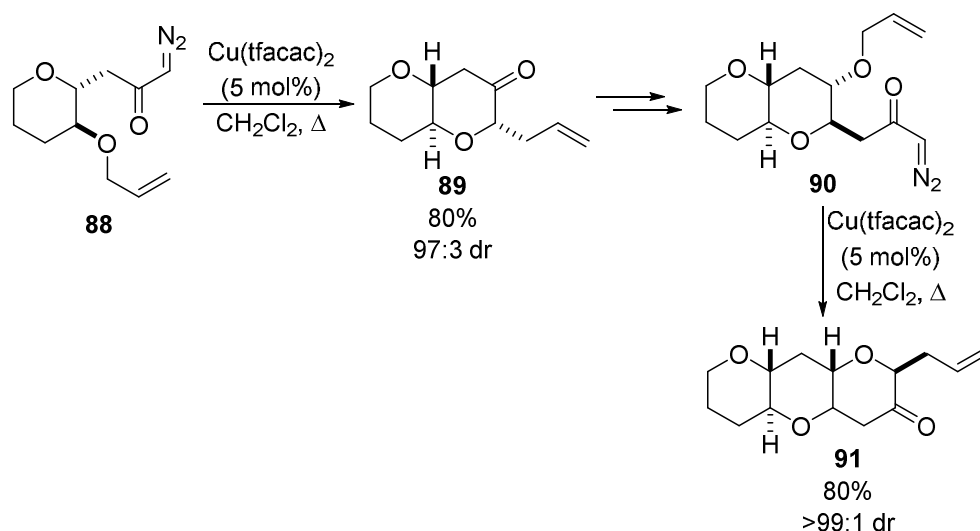

## Scheme 21. Diastereoselective synthesis of polypyran motifs

Doyle and co-workers found that competing [1,2]- and [2,3]-rearrangements were observed when diazoacetate substituted tetrahydropyran-4-ones such as **92** undergo rhodium-catalyzed intramolecular oxonium ylide formation and rearrangement (Scheme 22).<sup>36</sup> The poor selectivity observed for both rearrangement products **93** and **94** was independent of the catalyst structure, suggesting these reactions proceed through a metal-free ylide species. Moreover the modest diastereoselectivity observed in each case reflects the axial-equatorial conformational isomer distribution of the reacting diazoacetate.

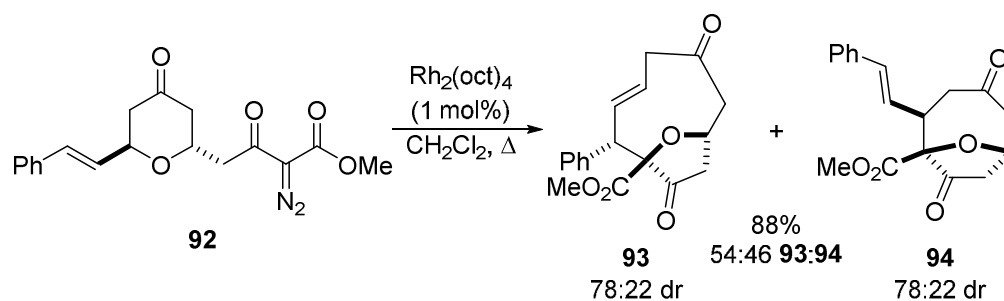

Scheme 22. Competing [1,2]- and [2,3]-rearrangements

Tae and co-workers have reported the use of alkynes as gold-carbenoid precursors in intramolecular oxonium ylide formations.<sup>37</sup> Treating propargylic ethers **95** with a gold (I) catalyst in the presence of stoichiometric oxidant **97** generates gold carbenoids **98**, which can undergo intramolecular oxonium ylide formation and subsequent [2,3]-rearrangement into dihydrofuranone derivatives **99** in modest yields (Scheme 23). The diastereoselectivity of the process was dependent on the nature of the propargylic substituent. Electron-rich aryl (R = 4-MeOC<sub>6</sub>H<sub>4</sub>) or heteroaryl (R = 2-furyl) groups gave the *anti*-product exclusively, whereas various alkyl substituents gave lower levels of diastereoselectivity (61:39 to 80:20 dr). Tang and co-workers have reported a related gold-catalyzed rearrangement of benzannulated propargylic ethers to form dihydrobenzofuranones under similar oxidative conditions.<sup>38</sup> Additionally, two diastereoselective examples utilizing carbocyclic aliphatic tethers were

investigated, with the resulting fused bicyclic tetrahydrofuranones formed in good yields as single diastereoisomers.

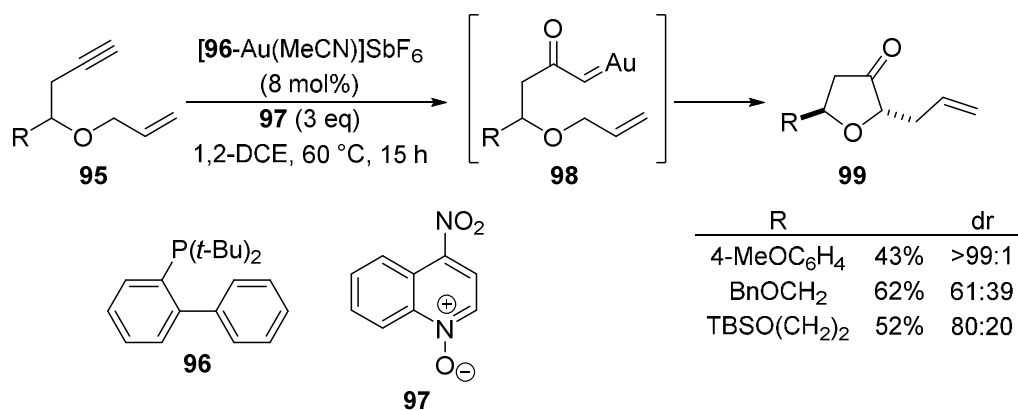

Scheme 23. Alkynes as gold carbenoid precursors

Boyer has utilized *N*-tosyl triazoles as alternatives to diazo compounds for the generation of rhodium carbenoids.<sup>39</sup> For example, treating **100** with catalytic Rh<sub>2</sub>(OAc)<sub>4</sub> results in decomposition of the triazole ring with release of nitrogen to form intermediate rhodium carbenoid **101**. Subsequent *in situ* oxonium ylide formation and diastereoselective [2,3]-rearrangement followed by hydrolysis over basic alumina of the resultant *N*-tosyl dihydrofuran imine allowed isolation of dihydrofuranone *ent*-**64** in 78% yield and >95:5 dr (Scheme 24a). A range of *C*(5) alkyl substituents was tolerated in this process giving dihydrofuranones in high yields and excellent dr, however incorporation of a *C*(5)-phenyl substituent gave the product in a reduced 83:17 dr. A small number of 2,2-disubstituted dihydrofuran-3-ones could also be synthesized using an increased catalyst loading of 15 mol% Rh<sub>2</sub>(OAc)<sub>4</sub>, with the products formed in reasonable yields with high levels of diastereoselectivity. This methodology was subsequently applied to the total synthesis of the acetogenin (+)-petromyroxol **104**.<sup>40</sup> Treatment of enantiomerically pure triazole **102** under the previously optimized conditions gave *anti*-tetrahydrofuranone **103** as a single

diastereoisomer, which was converted into (+)-petromyroxol **104** in four further steps (Scheme 24b).

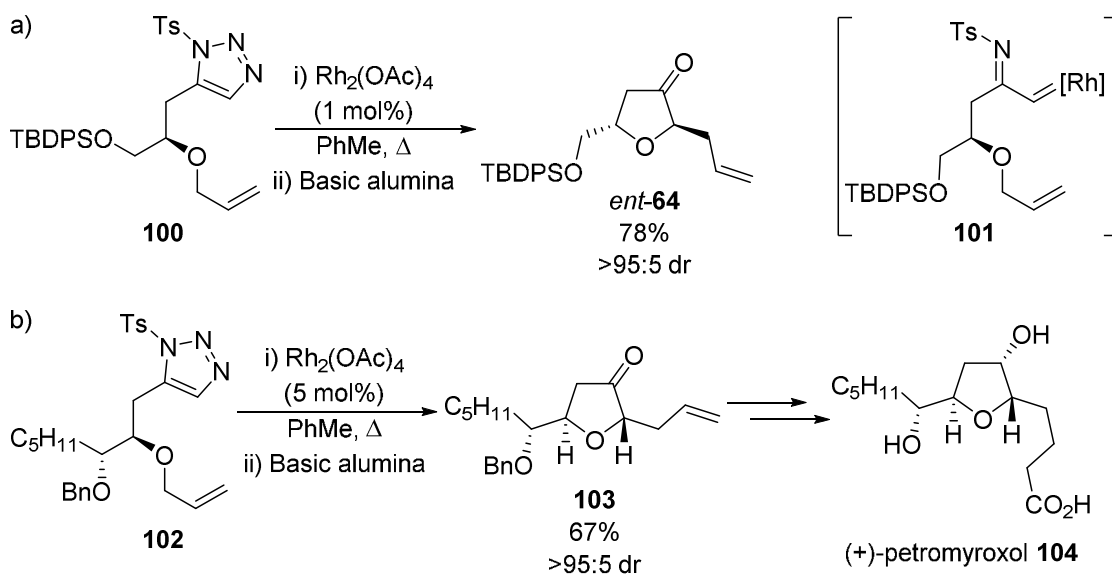

**Scheme 24.** a) Diastereoselective synthesis of dihydrofuran-3-imines from *N*-tosyl 1,2,3-triazoles. b) Application in natural product synthesis

A series of *C*(2) tetrasubstituted tetrahydrofurans was accessible through the rhodium-catalyzed decomposition of triazoles such as **105** (Scheme 25).<sup>41</sup> As previously, the intermediate *N*-tosyl imine **106** was unstable to purification but was readily hydrolyzed into aldehyde **107** in an overall 88% yield as a single diastereoisomer. The reaction tolerates a range of functionalized *C*(5) alkyl substituents, forming the synthetically useful products in high yields and excellent diastereoselectivity. The catalytic rearrangement of an *O*-propargylic triazole was also possible, with the corresponding allenyl tetrahydrofuran formed in excellent yield but with a slightly reduced dr (6:1).

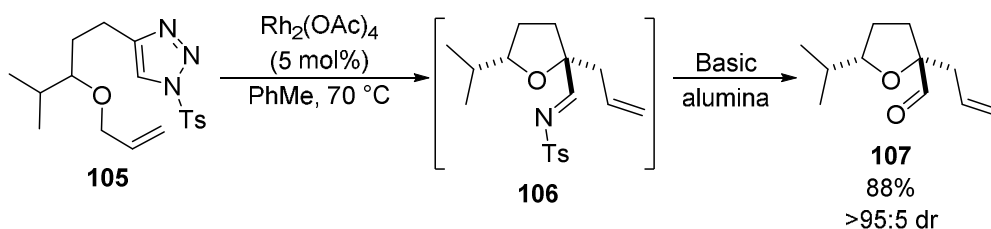

**Scheme 25.** Diastereoselective synthesis of *C*(2)-tetrasubstituted saturated heterocycles



1  
2  
3  
4  
5  
6  
7  
8  
9  
10  
11  
12  
13  
14  
15  
16  
17  
18  
19  
20  
21  
22  
23  
24  
25  
26  
27  
28  
29  
30  
31  
32  
33  
34  
35  
36  
37  
38  
39  
40  
41  
42  
43  
44  
45  
46  
47  
48  
49  
50  
51  
52  
53  
54  
55  
56  
57  
58  
59  
60

**2.1.3 Enantioselective intramolecular oxonium ylide formation and [2,3]-rearrangement.** In 1992 McKervey and McCann reported the first enantioselective intramolecular [2,3]-rearrangement of allylic oxonium ylides in which the stereochemistry is derived from the catalyst.<sup>42</sup> The catalytic decomposition of diazo compound **108** (R = Me) using rhodium complexed with (*S*)-BNP **110** followed by oxonium ylide formation and [2,3]-rearrangement gave substituted benzofuranone **109** in 92% yield and 30% ee (Scheme 26). Hodgson subsequently showed that alkyl substituted phosphate ligand **111** gave higher levels of enantioselectivity, albeit in lower yield.<sup>43</sup> Moody and co-workers tested a range of pyrrole 2-carboxylate ligands with chiral *N*-substituents in the same reaction, but only low levels of enantioselectivity were observed.<sup>44</sup> An extensive study by McKervey and co-workers assessed a range of different chiral ligands in this process with (*S*)-PTTL **112**, derived from (*S*)-*tert*-leucine, giving product **109** (R = H) in 96% yield and 60% ee.<sup>45</sup> Hashimoto and co-workers found that the enantioselectivity of the reaction using **112** could be improved by performing the reaction in toluene at low temperature (−10 °C), although the product yield was reduced (Scheme 26).<sup>46</sup>

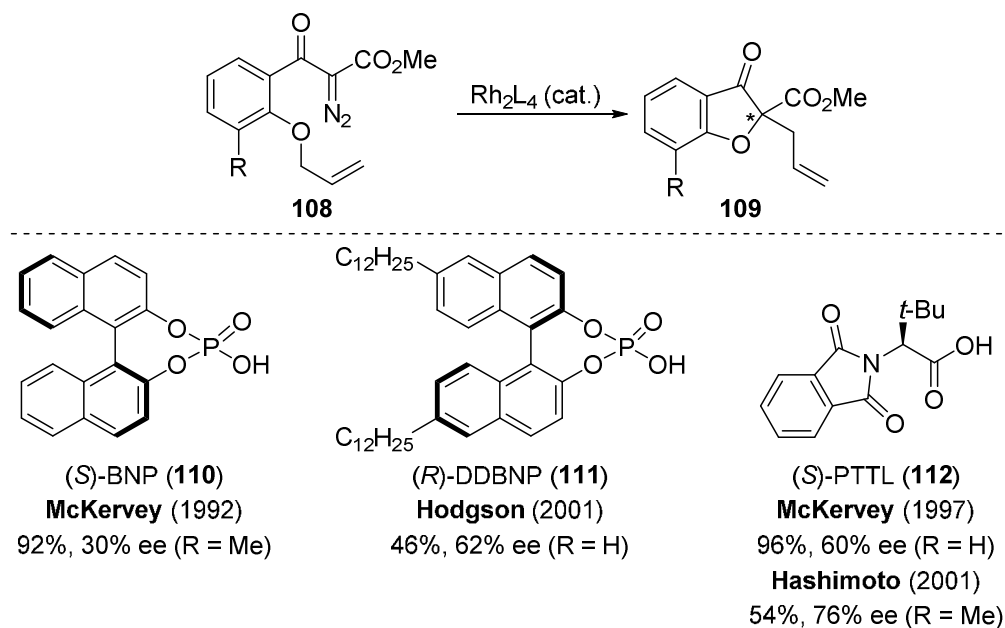

**Scheme 26.** Enantioselective [2,3]-rearrangement of oxonium ylides using chiral rhodium complexes

1  
2  
3 Calter and Sugathapla reported that diazoacetal **113** reacted with the rhodium complex of  
4  
5 ligand **115** to give bicyclic tetrahydrofuran derivative **114** in 47% yield and 34% ee (Scheme  
6  
7 27).<sup>47</sup> Hashimoto and co-workers later reported an improved variant of this reaction through  
8  
9 screening of a wide range of chiral carboxylate Rh(II) complexes.<sup>48</sup> The optimal catalytic  
10  
11 system used fluorinated ligand **116** to form rearranged product **114** in 72% yield and an  
12  
13 impressive 93% ee.  
14  
15

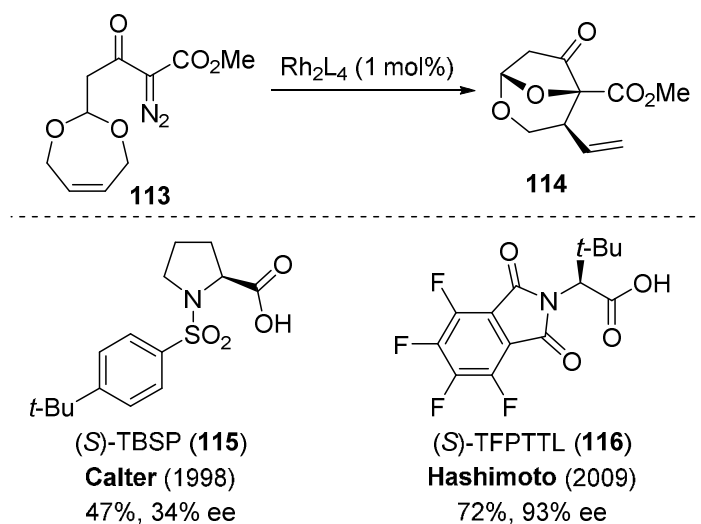

Scheme 27. Enantioselective synthesis of bicyclic tetrahydrofuran derivatives

37  
38  
39  
40  
41  
42  
43  
44  
45  
46  
47  
48  
49  
50  
51  
52  
53  
54  
55  
56  
57  
58  
59  
60

Clark and co-workers screened a number of C<sub>2</sub>-symmetric chiral diimines in the copper-catalyzed reaction of diazoketone **117**, with ligand **118** giving dihydrofuranone product **119** in 62% yield and reasonable 57% ee (Scheme 28).<sup>49</sup> The substitution pattern around the diazoketone had a large impact on the enantioselectivity observed. For example, introduction of an  $\alpha$ -methyl substituent adjacent to the carbonyl had little effect, whereas placing a methyl group in either the  $\beta$ -position or the 2-position of the allyl group led to a dramatic drop in enantioselectivity. Benzannulation of the substrate also led to reduced levels of enantioselectivity in the resulting benzofuranone products.

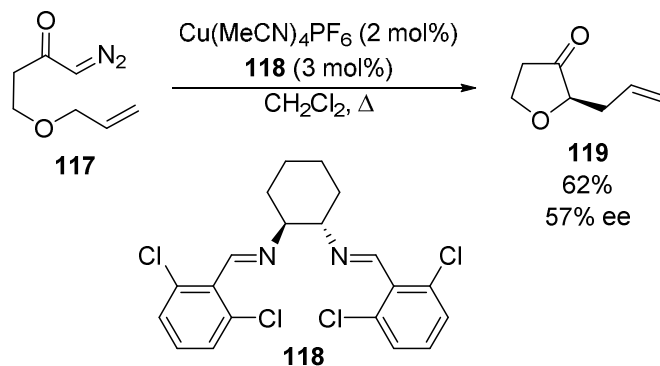

**Scheme 28.** Copper-catalyzed enantioselective intramolecular [2,3]-rearrangement of **117**

15  
16  
17  
18  
19  
20  
21  
22  
23  
24  
25  
26  
27  
28  
29  
30  
31  
32  
33  
34  
35  
36  
37  
38  
39  
40  
41  
42  
43  
44  
45  
46  
47  
48  
49  
50  
51  
52  
53  
54  
55  
56  
57  
58  
59  
60

Doyle and co-workers reported the enantioselective [2,3]-rearrangement of a 13-membered ring oxonium ylide formed from decomposition of diazo compound **120** in the presence of a copper catalyst and BOX ligand **121** (Scheme 29).<sup>8,50</sup> The reaction was selective for [2,3]-rearrangement over competing cyclopropanation (89:11 **123**:**122**), allowing macrocyclic ether **123** to be isolated as a single diastereoisomer in 35% yield and 65% ee. The relative stereochemistry was determined by analysis of  $\gamma$ -lactone **124**, which was formed in excellent yield upon hydrogenation of macrocycle **123**.

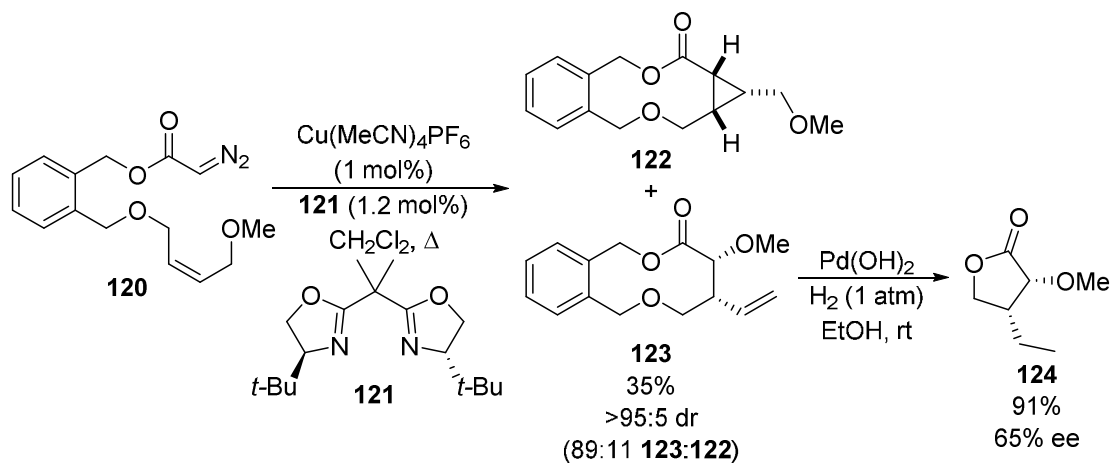

**Scheme 29.** Enantioselective macrocyclic ether synthesis

## 2.2 Ammonium ylides.

The [2,3]-rearrangement of allylic ammonium ylides leads to the formation of substituted  $\alpha$ -amino acid derivatives. Despite the huge synthetic potential of this process, the development of a catalytic enantioselective variant using intermediate metal carbenoids has remained elusive, with only diastereoselective examples reported to date.

**2.2.1 Intermolecular ammonium ylide formation and [2,3]-rearrangement.** In 1981 Doyle and co-workers reported the first diastereoselective intermolecular ammonium ylide formation and [2,3]-rearrangement from the catalytic decomposition of a diazo compound.<sup>51</sup> Reacting ethyl diazoacetate **20** with  $\text{Rh}_2(\text{OAc})_4$  (0.5 mol%) and an excess of tertiary allylic amine **125** gave rearranged  $\alpha$ -amino acid derivative **126** in 59% yield as a 75:25 mixture of *anti:syn* diastereoisomers (Scheme 30). Che and co-workers have performed a similar reaction using a ruthenium porphyrin based catalyst, with the rearranged product being obtained with same level of diastereoselectivity.<sup>52</sup>

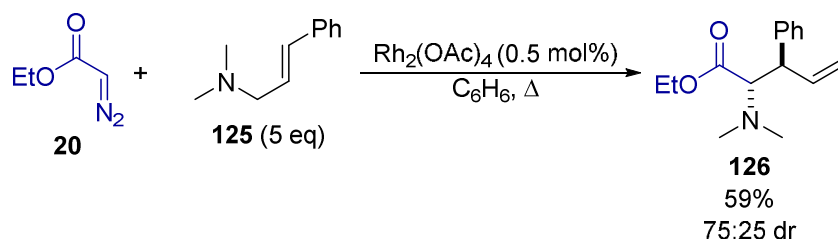

**Scheme 30.** Intermolecular diastereoselective allylic ammonium ylide generation and [2,3]-rearrangement

In 2003 Sweeney and co-workers investigated the [2,3]-rearrangement of ammonium ylides **128** generated from the reaction of tetrahydropyridine **127** and ethyl diazoacetate **20** (Scheme 31a).<sup>53</sup> In this case, using  $\text{Rh}_2(\text{OAc})_4$  as the catalyst gave low yields and a complex mixture of products. Copper catalysts were more selective, with  $\text{Cu}(\text{acac})_2$  (20 mol%) promoting ammonium ylide formation and subsequent *endo*-selective [2,3]-rearrangement to give *syn*-pyrrolidine **129** in 59% yield as a single diastereoisomer. The use of  $\alpha$ -keto diazoacetates such as **130** was also investigated in this process, forming functionalized pyrrolidine **131**

containing a quaternary stereocenter in good yields with reasonable levels of diastereoselectivity (Scheme 31b).<sup>54</sup> The use of a bicyclic tetrahydropyridine was also trialed, but the desired bicyclic rearrangement product was only formed in low yields and the stoichiometric base-mediated rearrangement of the pre-formed ammonium ylide was more efficient in this case.<sup>55</sup>

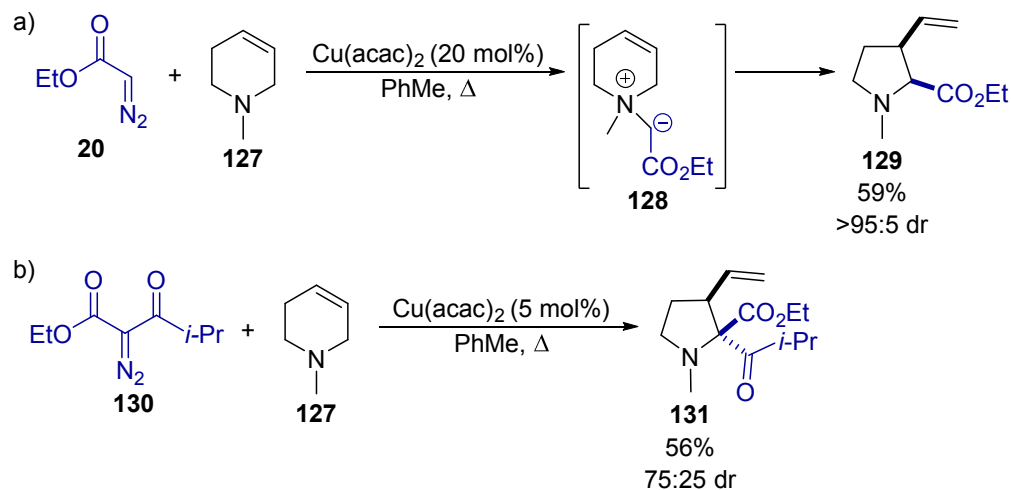

Scheme 31. Copper-catalyzed synthesis of substituted pyrrolidines

**2.2.2. Intramolecular ammonium ylide formation and [2,3]-rearrangement.** In 1994 Clark and co-workers reported the first diastereoselective [2,3]-rearrangement of an ammonium ylide generated from the intramolecular reaction of a metal carbenoid and an cyclic allylic amine.<sup>56</sup> Treating diazoketone **132** with  $\text{Cu}(\text{acac})_2$  (2 mol%) generated *syn*-ammonium ylide **133**, which underwent [2,3]-rearrangement to give indolizidine **134** as a single diastereoisomer. Upon treatment with silica gel indolizidine **134** underwent complete epimerization into the opposite diastereoisomer **135**, which was isolated in 72% yield (Scheme 32). This methodology was subsequently applied to the diastereoselective synthesis of a small range of pyrrolizidine, indolizidine and quinolizidine motifs.<sup>57</sup> Acyclic substrates containing a stereogenic center on the tether connecting the allylic amine and diazoketone

also undergo metal-catalyzed ylide formation and [2,3]-rearrangement to form cyclic amine products in good yields but with little diastereoselectivity.<sup>58</sup>

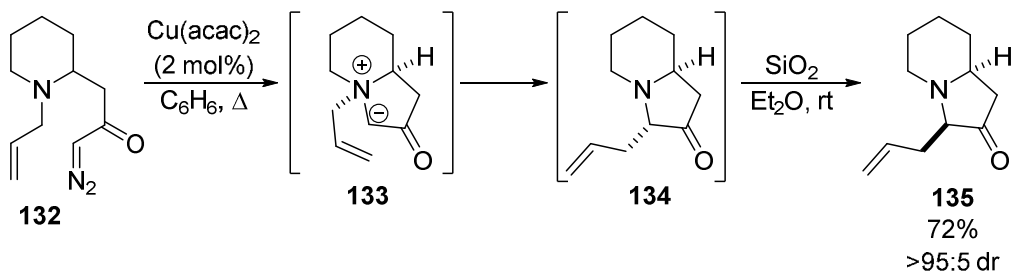

**Scheme 32.** Diastereoselective synthesis of indolizidines *via* intramolecular ylide generation and [2,3]-rearrangement

Clark and co-workers applied intramolecular ammonium ylide formation and [2,3]-rearrangement to the asymmetric synthesis of the CE ring system of the manzamine and ircinal families of marine alkaloids.<sup>57,59</sup> Diazoketone **136**, prepared in four steps from (*S*)-prolinol, was treated with  $\text{Cu}(\text{acac})_2$  (2 mol%) to form the bicyclic rearrangement product **137** in 56% yield (Scheme 33). Diastereoselective reduction of ketone **137** with L-Selectride<sup>®</sup> gave alcohol **138** in 75% yield and >98% ee, confirming essentially complete transfer of stereochemistry during the [2,3]-rearrangement of the intermediate spiro-fused ammonium ylide.

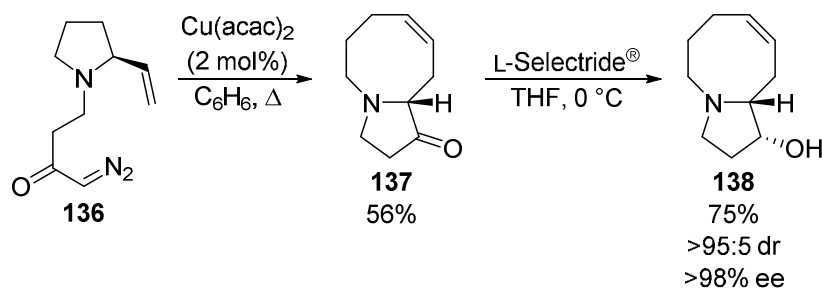

**Scheme 33.** Asymmetric synthesis of the CE ring system of the manzamine and ircinal alkaloids

McMills and co-workers reported an analogous method for the synthesis of medium-sized azacane rings.<sup>60</sup> L-Proline derived diazoketone **139** also undergoes ylide formation and [2,3]-rearrangement with transfer of stereochemistry in the presence of  $\text{Cu}(\text{hfacac})_2$  (15 mol%) to

form azacane **140** in 70% yield and 98% ee (Scheme 34). However, in this case competing [1,2]-Stevens rearrangement into bicycle **141** was also observed (70:30 **140:141**), which is attributed to the increased tether length of diazoketone **139** compared with **136**.

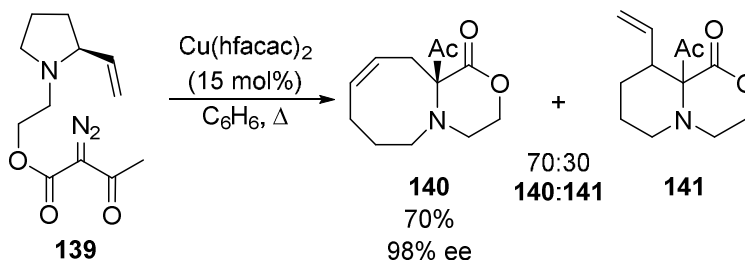

**Scheme 34.** Catalytic asymmetric synthesis of medium sized azacane rings

Rowlands and Barnes have investigated the copper-catalyzed aziridinium ylide generation and [2,3]-rearrangement of diazo compound **142** (Scheme 35).<sup>61</sup> Treating **142** with catalytic  $\text{Cu}(\text{acac})_2$  allowed indolizine **145** to be isolated in only 21% yield but as a single diastereoisomer. The low yield is proposed to be partially due to the slow rate of inversion of configuration at nitrogen in aziridines. Starting material **142** exists as a mixture of nitrogen invertomers (43:57) that react to give intermediate aziridinium ylides **143** and **144**. In this case, only ylide **143** derived from the minor *N*-invertomer of **142** has the correct geometry to undergo [2,3]-rearrangement.

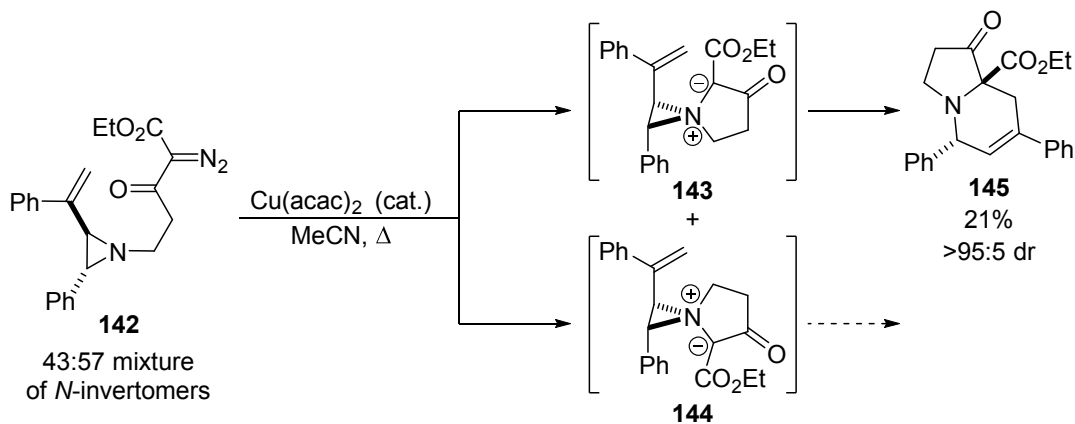

**Scheme 35.** Copper-catalyzed generation and rearrangement of aziridinium ylides



## 2.3 Sulfonium ylides

The [2,3]-rearrangement of sulfonium ylides, sometimes referred to as the Doyle-Kirmse reaction, generated from the reaction of a metal carbenoid with an allylic sulfide has been widely studied. While high diastereo- and/or (*E*)/(*Z*)-selectivity is attainable, the development of catalytic enantioselective variants of this reaction is particularly challenging. This is due to the fact that the catalyst must first distinguish between the heterotopic lone pairs of the sulfur atom and then promote a selective [2,3]-rearrangement reaction in which the stereochemical information is efficiently transferred from sulfur to carbon.<sup>62</sup>

**2.3.1 Diastereoselective intermolecular sulfonium ylide formation and [2,3]-rearrangement.** One of the early examples of a stereoselective [2,3]-rearrangement utilizing the catalytic *in situ* formation of sulfonium ylides was reported by Grieco *et al.* in 1973.<sup>63</sup> Treating sulfide **147** with dimethyl diazomalonate **146** and catalytic CuSO<sub>4</sub> gave product **148** in 70% yield and an 90:10 *E:Z* isomeric ratio (Scheme 36).

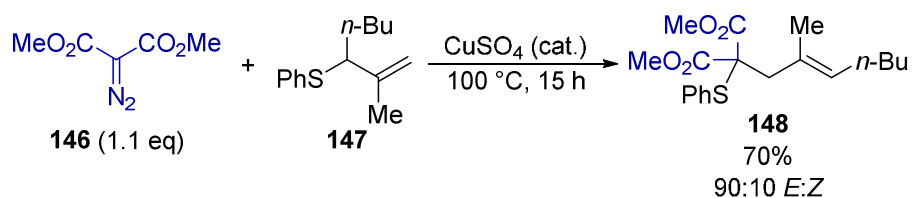

Scheme 36. Copper-catalyzed [2,3]-rearrangement using diazomalonate **146**

Yoshimoto and co-workers demonstrated that cephalosporin derivatives such as **149** undergo completely diastereoselective ring-contraction into penicillin derivatives through the copper-catalyzed reaction with ethyl diazoacetate followed by [2,3]-rearrangement (Scheme 37a).<sup>64</sup> Thomas and co-workers subsequently utilized the diastereoselective [2,3]-rearrangement of sulfonium ylides to form a series of functionalized penicillanates.<sup>65</sup> For example, treating diazopenicillanate **151** with allylic sulfide **152** and Cu(acac)<sub>2</sub> (11 mol%) resulted in formation of 6,6-disubstituted penicillanate **153** in 65% yield and 87:13 dr (Scheme 37b). However, the

reaction using the corresponding allylic selenide under the same conditions resulted in formation of the product with no diastereoselectivity.

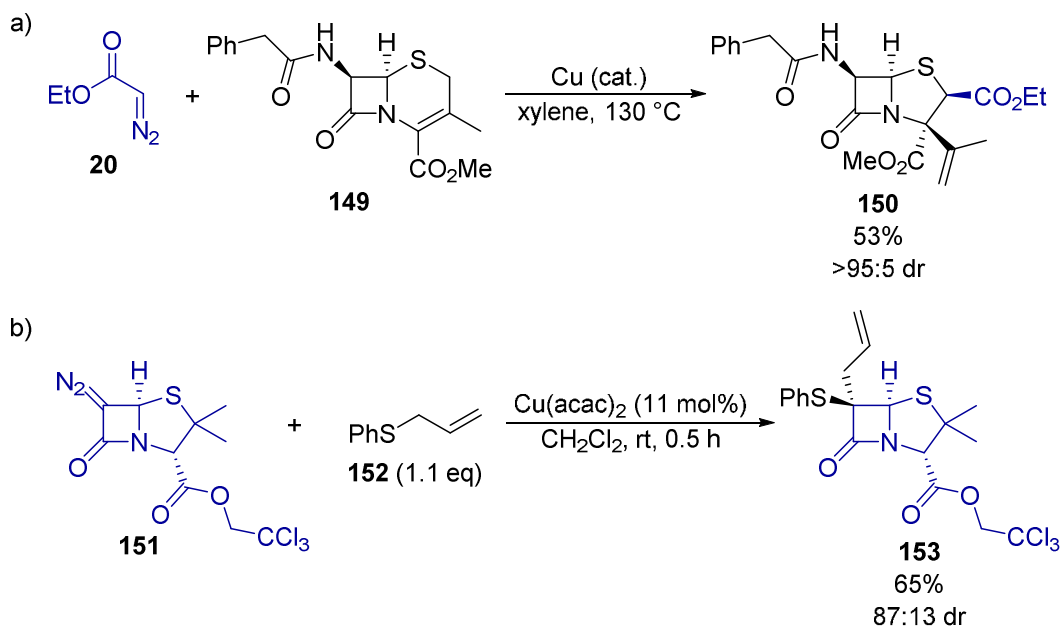

**Scheme 37.** a) Ring-contraction of cephalosporin core into a penicillin derivative; b) Functionalization of diazopenicillanates **151**

Early attempts to utilize [2,3]-rearrangements in ring-expansion reactions, for example copper bronze-promoted decomposition of diazomalonate **146** followed by reaction with cyclic sulfide **154** and subsequent [2,3]-rearrangement, gave ring-expanded product **155** in 53% yield (Scheme 38).<sup>66</sup> However, subsequent attempts to explore the scope and utility of such ring-expansion processes have met with difficulties due to competing [1,2]-rearrangements and elimination reactions leading to mixtures of products.<sup>67,68,69,70,71</sup>

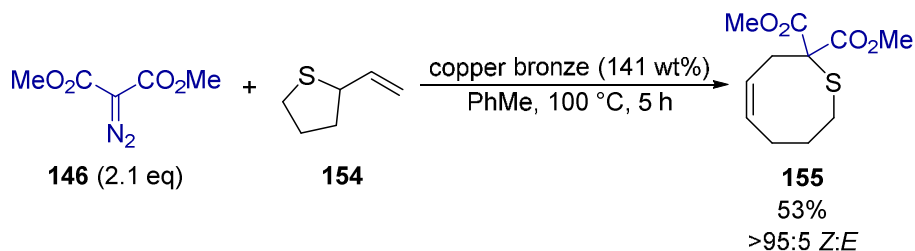

**Scheme 38.** Ring-expansion of cyclic sulfide **154**

1  
2  
3 Xu and co-workers demonstrated that sulfonium ylides derived from the rhodium-catalyzed  
4  
5 reaction between ethyl 2-diazo-3,3,3-trifluoropropanoate **156** and a wide range of allylic  
6  
7 sulfides undergo moderately diastereoselective [2,3]-rearrangements to form synthetically  
8  
9 useful  $\alpha$ -trifluoromethyl esters in high yields (Scheme 39a).<sup>72</sup> The scope of this process was  
10  
11 explored through the use of a wide range of functionalized allylic, propargyl, and allenyl  
12  
13 sulfides, forming the corresponding products in high yields in all cases, although only modest  
14  
15 levels of diastereoselectivity were obtained in most cases. The synthetic utility of the  
16  
17 products was demonstrated through conversion into trifluoromethyl substituted conjugated  
18  
19 dienes *via* oxidation of the sulfide with *m*-CPBA followed by thermal elimination of the  
20  
21 resulting sulfoxide. This reaction sequence was successfully applied to a range of the  
22  
23 rearranged sulfide products and was further utilized in the synthesis of trifluoromethyl epoxy-  
24  
25 retinal derivative **162** (Scheme 39b). Subsequent attempts to render this process  
26  
27 enantioselective by Müller and co-workers through use of a chiral rhodium catalyst were  
28  
29 unsuccessful, with only low levels of enantioselectivity obtained for a range of catalysts.<sup>73</sup>  
30  
31  
32  
33  
34  
35  
36  
37  
38  
39  
40  
41  
42  
43  
44  
45  
46  
47  
48  
49  
50  
51  
52  
53  
54  
55  
56  
57  
58  
59  
60

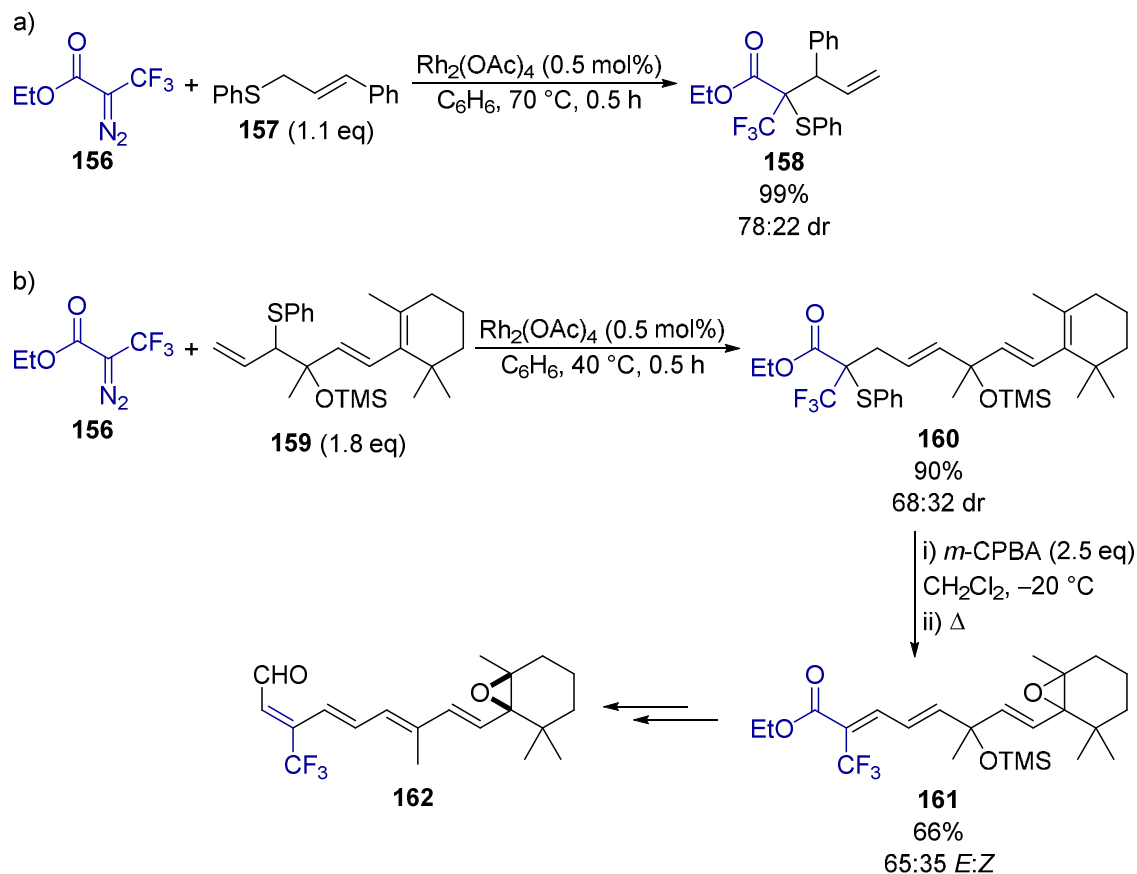

**Scheme 39.** [2,3]-Rearrangement of sulfonium ylides generated from rhodium-catalyzed decomposition of **156**. Configuration of the major diastereoisomer is unreported

33  
34  
35  
36  
37  
38  
39  
40  
41  
42  
43  
44  
45

In 2009, Davies and co-workers reported the first silver-catalyzed reaction between ethyl 2-diazo-2-phenylacetate and various allylic and propargylic sulfides.<sup>74</sup> A wide range of rearranged products was obtained in good yields, although when a substituted cinnamyl phenyl sulfide was used only low levels of diastereoselectivity were observed.

46  
47  
48  
49  
50  
51  
52  
53  
54  
55  
56  
57  
58  
59  
60

In 1999, Aggarwal and Van Vranken independently investigated the use of trimethylsilyl diazomethane **163** as a sulfonium ylide precursor.<sup>75</sup> Aggarwal and co-workers used  $\text{Rh}_2(\text{OAc})_4$  (1 mol%) to catalyze the reaction of trimethylsilyl diazomethane **163** with allylic sulfide **164** with [2,3]-rearrangement of the resulting sulfonium ylide forming *syn*-product **165** in 90% yield and 90:10 dr (Scheme 40).<sup>75a</sup> In this case an excess of **163** could be used and, unlike with alternative carbonyl-stabilized diazo compounds, slow addition was not

required. The scope of the process was examined using a small range of differentially substituted allylic sulfides, with the rearranged products formed in high yields with good levels of diastereoselectivity in each case. The use of a variety of chiral rhodium or copper catalysts in this process led to a decrease in diastereoselectivity and only low levels of enantioselectivity were obtained in all cases (up to 18% ee).

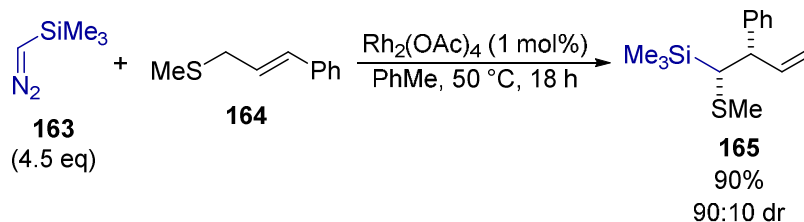

**Scheme 40.** Use of trimethylsilyl diazomethane **163** as a sulfonium ylide precursor

Van Vranken and co-workers also investigated the use of both  $\text{Rh}_2(\text{OAc})_4$  and  $\text{CuOTf}$  as catalysts for generation of sulfonium ylides through the decomposition of trimethylsilyl diazomethane **163**.<sup>75b</sup> In 2000,  $\text{dppeFeCl}_2$  (5 mol%) was reported to effectively catalyze the reaction between **163** and various allylic sulfides. For example, the reaction between **163** and cinnamyl phenyl sulfide **157** gave the rearranged product in 94% yield and 87:13 dr.<sup>75c</sup> This methodology has been applied to the synthesis of the meroterpene natural product ( $\pm$ )-3-hydroxybakuchiol **168** (Scheme 41).<sup>75d</sup> The iron-catalyzed reaction of **163** with allylic sulfide **166** was performed on a multi-gram scale to afford product **167** in 89% yield and 67:33, with subsequent manipulation of the  $\alpha$ -silyl thioether functionality resulting in the first reported synthesis of **168**. The use of various palladium catalysts has also been studied for the reaction between trimethylsilyl diazomethane **163** and allylic sulfides, however the yields and diastereoselectivity obtained are lower than those reported for the corresponding rhodium or iron-catalyzed processes.<sup>76</sup>

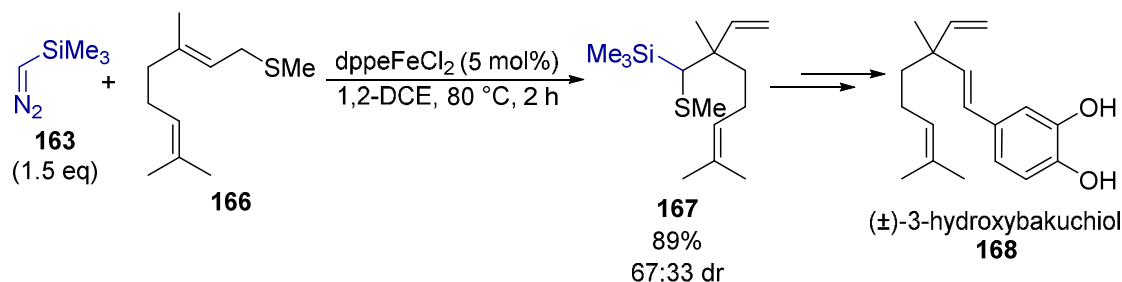

**Scheme 41.** Synthesis of ( $\pm$ )-3-hydroxybakuchiol **168**. The relative configuration of the major diastereoisomer is unreported

A number of alternatives to highly reactive diazo compounds have been investigated as metal carbenoid precursors for the formation of allylic sulfonium ylides. For example, triazoles act as masked diazo compounds and react with allylic sulfides in the presence of a rhodium catalyst.<sup>77</sup> The resulting sulfonium ylides undergo efficient [2,3]-rearrangement to form products in good yields, however the diastereoselectivity obtained with substituted allylic sulfides is low. In 2015, Wang and co-workers reported the use of highly strained cyclopropenes **169** as rhodium carbenoid precursors that could be trapped with allylic sulfides, with [2,3]-rearrangement of the resulting sulfonium ylides leading to the isolated products.<sup>78</sup> The reaction was demonstrated for a wide range of allyl sulfide substituents including *S*-aryl, heteroaryl, alkyl and allyl forming the rearranged products in excellent yields. Unfortunately, when substituted allylic sulfides such as **157** were used, low levels of diastereoselectivity were obtained although the yields remained high (Scheme 42). A range of alternative substituted cyclopropenes was also explored as well as the use of propargylic sulfides, but only modest levels of *E:Z* selectivity of the resulting allylic sulfides was obtained in either case. Furthermore, attempts to perform the reaction enantioselectively using a number of different chiral rhodium catalysts gave the rearranged products with only moderate levels of enantioselectivity (up to 53% ee).

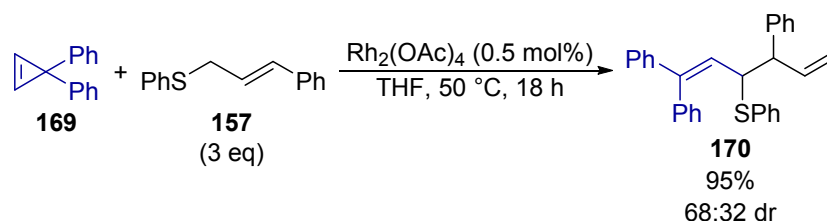

11 **Scheme 42.** Use of cyclopropenes as rhodium carbenoid precursors. Configuration of the major diastereoisomer  
12 is unreported

13  
14 Substituted alkynes have also been utilized as metal carbenoid precursors in catalytic [2,3]-  
15 rearrangements. Uemura and co-workers have developed the rhodium-catalyzed formation of  
16 sulfonium ylides and subsequent [2,3]-rearrangement starting from (2-furyl)-carbenoid  
17 precursors such as **171** and allylic sulfide **157** (Scheme 43).<sup>79</sup> The resulting substituted furan  
18 **172** is obtained in excellent yield as a single diastereoisomer, although the scope of this  
19 process was only explored for two examples.  
20  
21  
22  
23  
24  
25  
26  
27

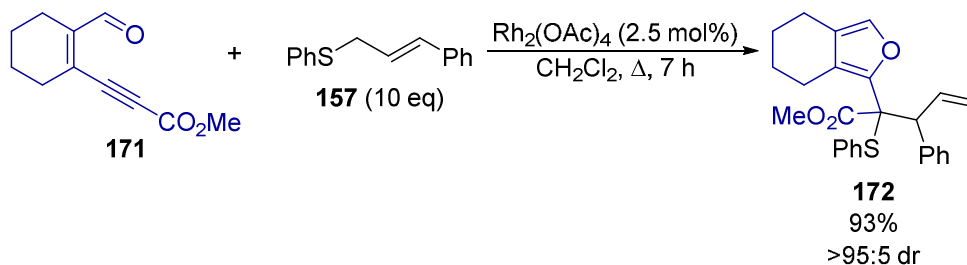

38 **Scheme 43.** Use of substituted alkynes as rhodium-carbenoid precursors. The relative configuration of the major  
39 diastereoisomer is unreported

40  
41 Davies and co-workers have reported the use of propargylic carboxylates as gold carbenoid  
42 precursors.<sup>80</sup> Treating propargylic acetate **173** with AuCl (5 mol%) in the presence of allylic  
43 sulfide **152** led to the unexpected formation of (*Z*)-**175** in 82% yield, with none of the  
44 expected [2,3]-rearrangement product **174** observed (Scheme 44). It is proposed that [2,3]-  
45 rearrangement product **174** undergoes a Cope rearrangement into **175**, although an alternative  
46 mechanistic pathway involving an oxygen-assisted 1,4-shift followed by elimination of AuCl  
47 could not be ruled out. The process is general for a range of aryl substituted propargyl  
48  
49  
50  
51  
52  
53  
54  
55  
56  
57  
58  
59  
60

carbonates and aryl allylic sulfides, forming the (*Z*)-isomers of the rearranged products in high yields.

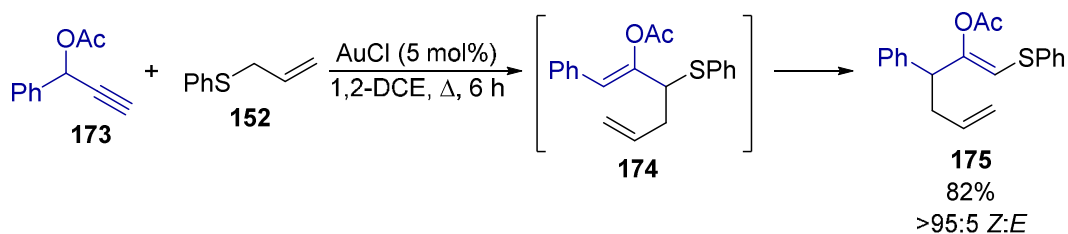

**Scheme 44.** Gold-catalyzed rearrangement of propargylic carboxylates

Building upon the initial work of Davies and co-workers for a related intermolecular process (*vide infra*),<sup>81</sup> Zhang and co-workers used a gold complex bearing sterically demanding ligand **177** to form [2,3]-rearrangement products such as **179** from the reaction of alkynes with allyl sulfides in the presence of stoichiometric oxidant **178** (Scheme 45a).<sup>82</sup> The process works for a range of different substituted alkynes and allyl sulfides, forming the rearranged products in high yields albeit with moderate diastereoselectivity when substituted allylic sulfides were used. The proposed general mechanism for this process involves *in situ* oxidation of allylic sulfide **157** with **178** to form allylic sulfoxide **181**, which can attack gold activated alkyne **180** (Scheme 45b). The resulting intermediate **182** can decompose into gold carbene **183**, which can recombine with released allylic sulfide **157** to form sulfonium ylide **184** that readily undergoes [2,3]-rearrangement into the observed products.



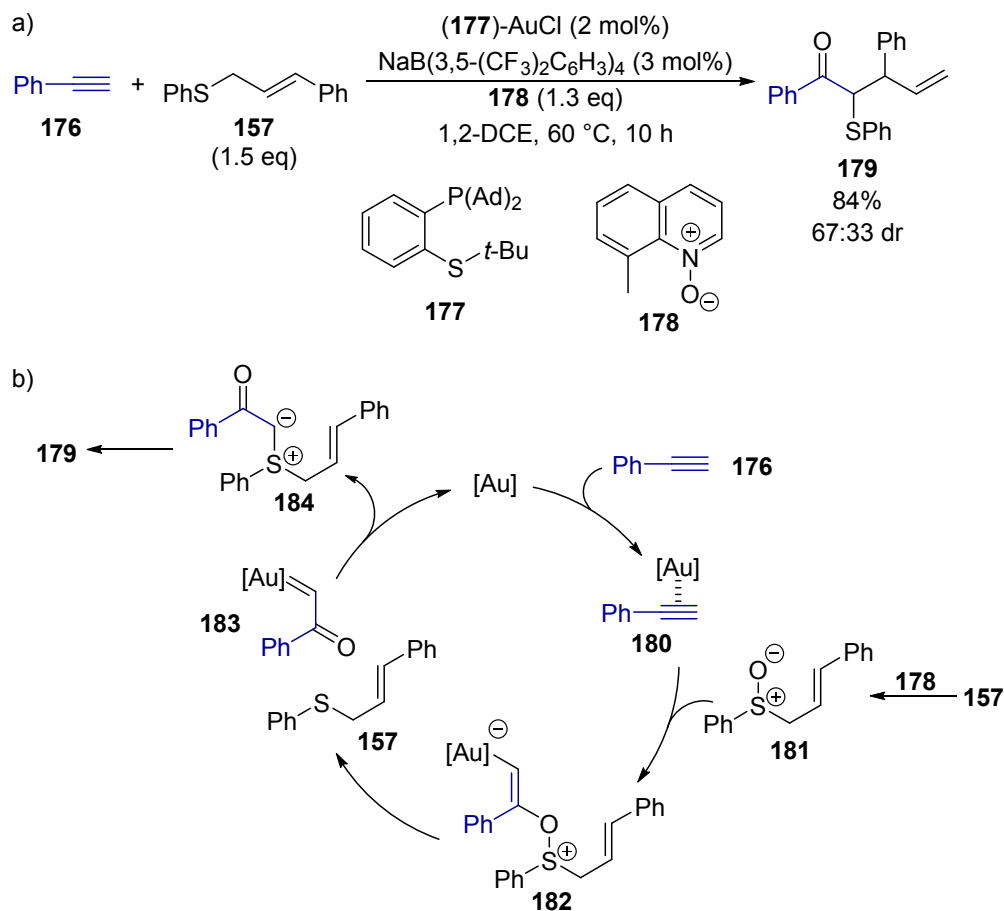

Scheme 45. Alkynes as metal carbenoid precursors

At the same time, Davies and co-workers reported a similar process using substituted ynamides as gold carbene precursors.<sup>83</sup> In this case pyridine *N*-oxide **187** was utilized as the stoichiometric oxidant alongside gold complexed with ligand **186** as the catalyst. The reaction proceeds under mild conditions to form the rearranged products in reasonable yields and importantly, unlike in many of the previously described cases, the reaction with substituted allylic sulfide **157** was highly diastereoselective (Scheme 46).

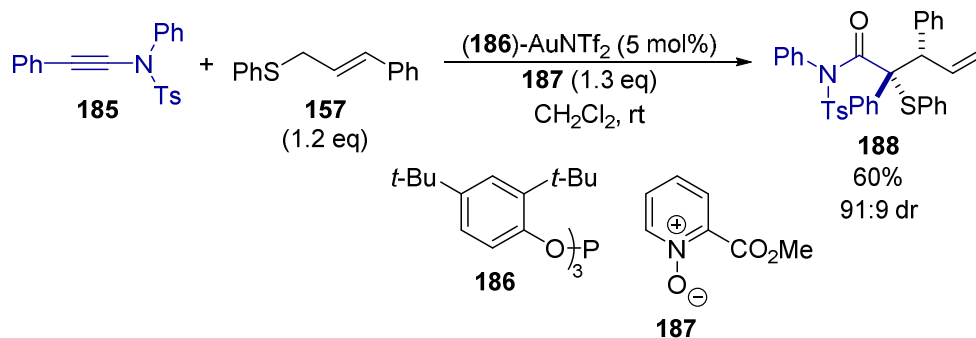

Scheme 46. Diastereoselective [2,3]-rearrangement using ynamide **185** as a gold carbene precursor

### 2.3.2 Enantioselective intermolecular sulfonium ylide formation and [2,3]-

**rearrangement.** The first attempted enantioselective [2,3]-rearrangement of a sulfonium

ylide was reported in 1995 by Uemura and co-workers.<sup>84</sup> The reaction between cinnamyl

phenyl sulfide **157** and ethyl diazoacetate **20** was trialed using both CuBOX complexes and

chiral rhodium catalysts, but in each case the rearranged product was formed with low levels

of diastereo- and enantioselectivity. The effect of the sulfide substituent on the

enantioselectivity of this process was subsequently investigated by McMillen and co-

workers.<sup>85</sup> The reaction between methyl diazoacetate **189** and various *S*-substituted allylic

sulfides were studied using CuOTf (2 mol%) and BOX ligand **121** (2.1 mol%) as the catalytic

system (Scheme 47a). Increasing the steric demand of the *S*-substituent increased the

enantioselectivity of the process. For example, small sulfide substituents such as methyl gave

no enantioselectivity whereas more sterically demanding 2,6-xylyl sulfide gave product **191**

in 62% yield and 52% ee. The use of a (+)-menthyl sulfide substituent as a chiral auxiliary in

combination with the chiral catalyst only gave a marginal increase in the enantioselectivity of

the process. Wang and co-workers have also investigated the influence of the allylic *S*-

substituent alongside various aryl substituted diazoacetates using the same CuBOX complex

as the catalyst (Scheme 47b).<sup>86</sup> In this case the best enantioselectivities were obtained using

2-tolyl allyl sulfide **193**, with the rearranged products formed in good yields and reasonable

enantioselectivity for a range of  $\alpha$ -aryl diazoacetates **192**. The highest enantioselectivity was

obtained using methyl 1-naphthylidiazooacetate, forming the corresponding product in 66% yield and 78% ee.

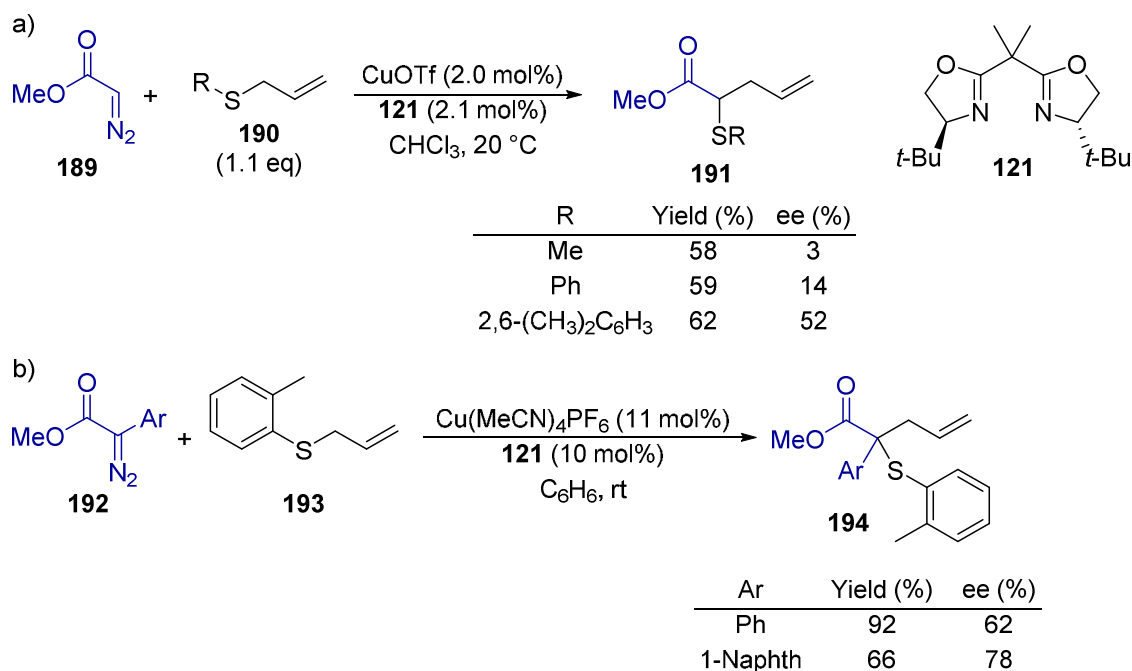

**Scheme 47.** Investigation of sulfide and diazoacetate substitution in enantioselective [2,3]-rearrangements of sulfonium ylides formed using BOX ligand **121**

The scope of the reaction has been further extended to the rearrangement of sulfonium ylides generated *in situ* from propargyl sulfides and  $\alpha$ -aryl diazoacetates, with the products formed with levels of selectivity comparable with the allylic substrates.<sup>87</sup> The rearrangement of allenyl sulfides with a range of chiral rhodium and copper catalysts has also been studied, with the products formed in generally good yields but with moderate levels of enantioselectivity.<sup>88</sup> These reactions have also been performed using water as the solvent using chiral rhodium catalysts, although the enantioselectivities obtained were lower.<sup>89</sup>

Rhodium and cobalt-based catalysts have also been utilized in the enantioselective [2,3]-rearrangement of sulfonium ylides. Hashimoto and co-workers used rhodium complexed with ligand **196** as a catalyst for the rearrangement of sulfonium ylides generated from the reaction of diazoacetates with allyl sulfides.<sup>90</sup> Increasing the steric demand of the diazoester led to

higher levels of diastereo- and enantioselectivity, for example reaction of **195** with cinnamyl phenyl sulfide **157** gave product **197** in excellent 94:6 dr and 53% ee (Scheme 48a). Katsuki and co-workers used cobalt and salen ligand **198** to catalyze the reaction between *t*-butyl diazoacetate **26** and allylic sulfide **157**, forming product **199** in 85:15 dr and 64% ee for the major *anti*-diastereoisomer (Scheme 48b).<sup>91</sup> Comparable levels of diastereo- and enantioselectivity were obtained in the reaction with a small range of substituted allylic sulfides. The use of (-)-menthyl diazoacetate to act as a chiral auxiliary alongside the cobalt salen catalyst gave the rearranged products with increased diastereo- and enantioselectivity.

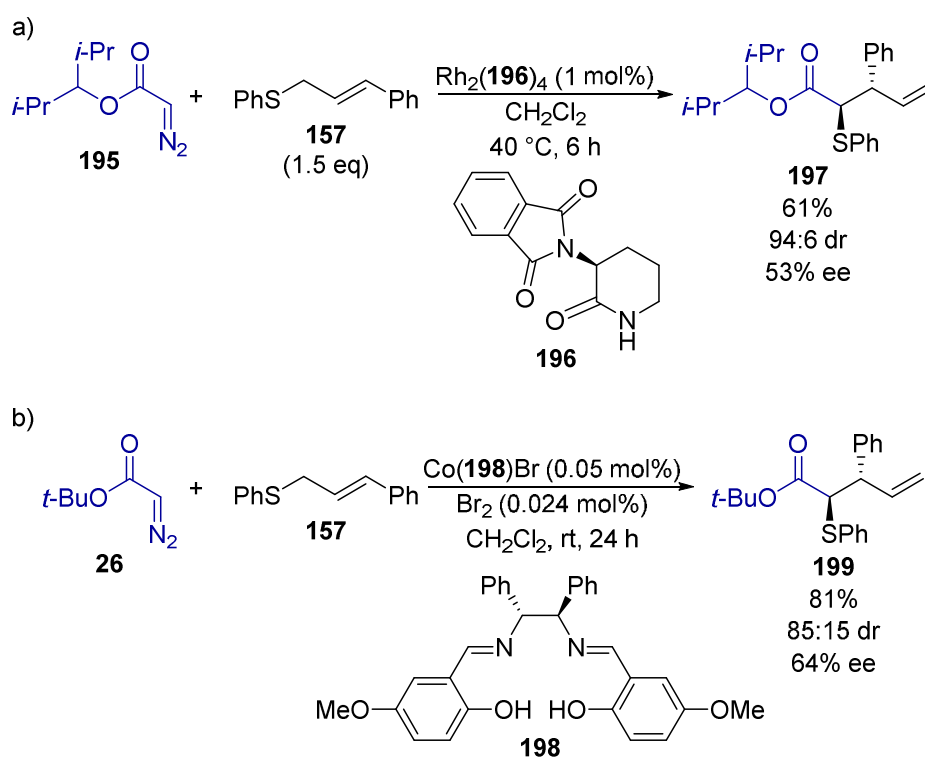

**Scheme 48.** a) rhodium and b) cobalt catalysts for the enantioselective rearrangement of sulfonium ylides

Wang and co-workers have reported the most enantioselective variant of this reaction to date using a series of diazo compounds bearing Oppolzer's camphor sultam chiral auxiliary.<sup>92</sup> The reaction between the diazo compounds and an allylic sulfide is efficiently catalyzed by copper bearing salen ligand **202**, with the resulting chiral sulfonium ylides undergoing highly

1  
2  
3 stereoselective [2,3]-rearrangements. For example, reaction of diazo compound **200** with  
4 allylic sulfide **201** followed by reduction of rearranged product **203** with LiAlH<sub>4</sub> to remove  
5 the chiral auxiliary gave alcohol **204** in 72% yield and 92% ee (Scheme 49a). The reaction  
6 was applicable to  $\alpha$ -alkyl, alkenyl and aryl substituted diazo compounds with the  
7 corresponding alcohol products formed in high yields with good levels of enantioselectivity.  
8 Attempts to improve the process through double-asymmetric induction using a chiral salen  
9 ligand in conjunction with the auxiliary did not offer any appreciable advantages in terms of  
10 either yield or enantioselectivity. Moreover, using either enantiomer of a chiral salen ligand  
11 in the reaction between **200** and **201** gave the same major enantiomer of alcohol **204** in 80%  
12 ee in both cases, suggesting that the asymmetry of the process is induced solely by the chiral  
13 auxiliary and that a ligand-bound catalyst is not involved in the rearrangement step. The  
14 scope of this process was further extended to the reaction of a range of chiral sultam  
15 containing diazo compounds with propargyl sulfides, forming allenyl alcohols such as **206** in  
16 good yields with high levels of enantioselectivity (Scheme 49b).  
17  
18  
19  
20  
21  
22  
23  
24  
25  
26  
27  
28  
29  
30  
31  
32  
33  
34  
35  
36  
37  
38  
39  
40  
41  
42  
43  
44  
45  
46  
47  
48  
49  
50  
51  
52  
53  
54  
55  
56  
57  
58  
59  
60

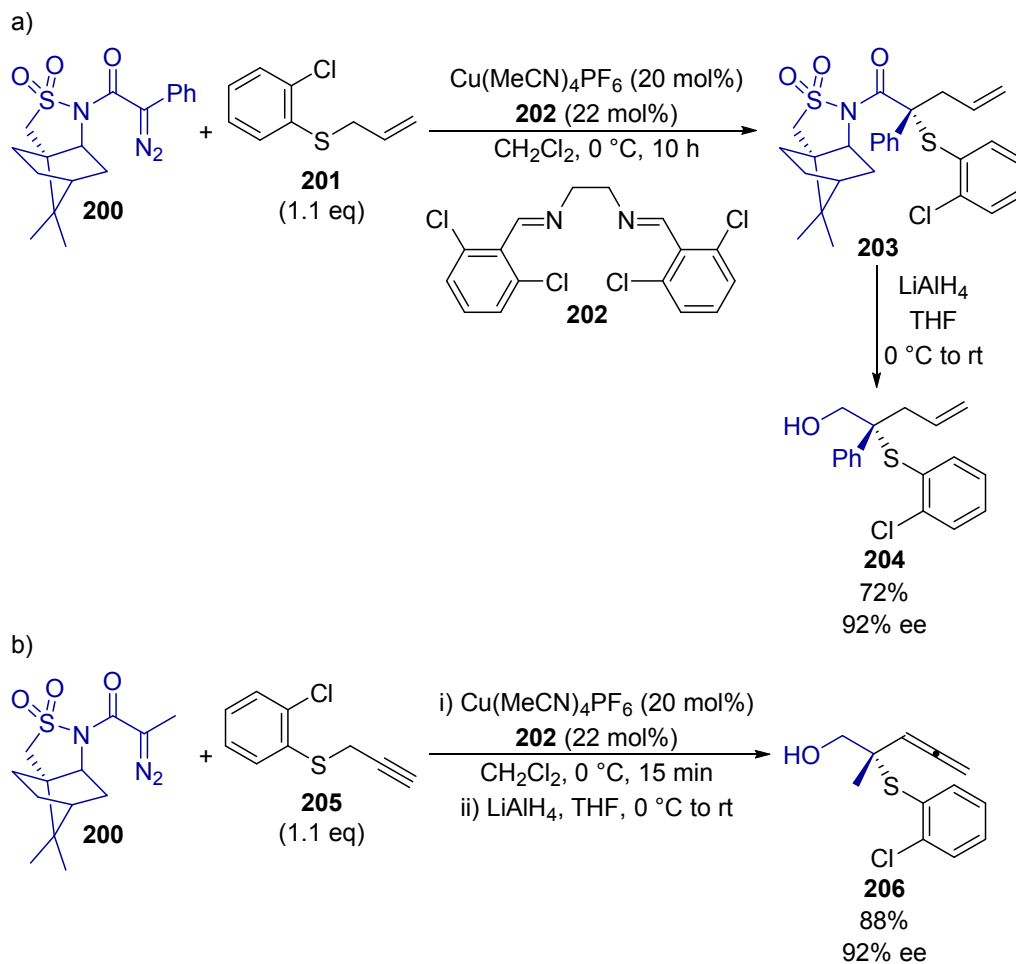

**Scheme 49.** Auxiliary controlled reactions of a) allylic and b) propargyl sulfides

Wee and co-workers investigated the ability of remote stereocenters within the allylic sulfide to influence the stereoselectivity in the rhodium-catalyzed reaction with diazoacetates. However, this approach proved to be challenging and only modest levels of enantioselectivity were achieved.<sup>93</sup>

**2.3.3 Diastereoselective intramolecular sulfonium ylide formation and [2,3]-rearrangement.** Kido and co-workers have extensively studied the intramolecular reaction of allylic sulfides containing tethered stabilized diazo functionality for the diastereoselective synthesis of substituted cyclic systems. Early examples made use of allylic sulfides such as **207**, which was synthesized by acylation of the corresponding alcohol with mono-ethyl

malonate followed by diazotization.<sup>94</sup> Treating allylic sulfide **207** with  $\text{Rh}_2(\text{OAc})_4$  (1 mol%) resulted in the intramolecular formation of eight-membered cyclic sulfonium ylide **208**, which then undergoes [2,3]-rearrangement to form  $\gamma$ -butyrolactone **209** in 70% yield as a single diastereoisomer (Scheme 50). The same methodology was also applied to the synthesis of related  $\delta$ -valerolactones, but the yields and diastereoselectivity were reduced.<sup>95,96</sup> However, further investigation found that increasing the complexity and substitution of the substrates helped to improve the diastereoselectivity of  $\delta$ -lactone formation. For example, a series of structurally complex polycyclic bridged  $\delta$ -lactones such as steroid derivative **211** were synthesized in high yields as single diastereoisomers (Scheme 51).<sup>97</sup> Altering the tether length in the system also allowed a small number of fused bicyclic seven-membered lactones to be synthesized with good levels of diastereoselectivity.<sup>98</sup>

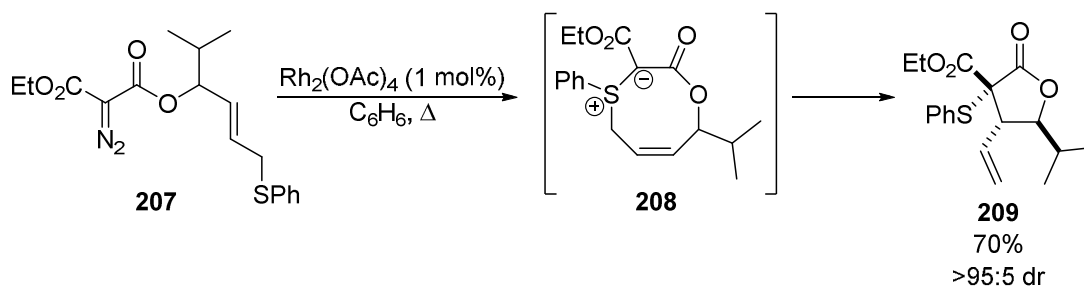

Scheme 50. Intramolecular [2,3]-rearrangement to form  $\gamma$ -butyrolactones

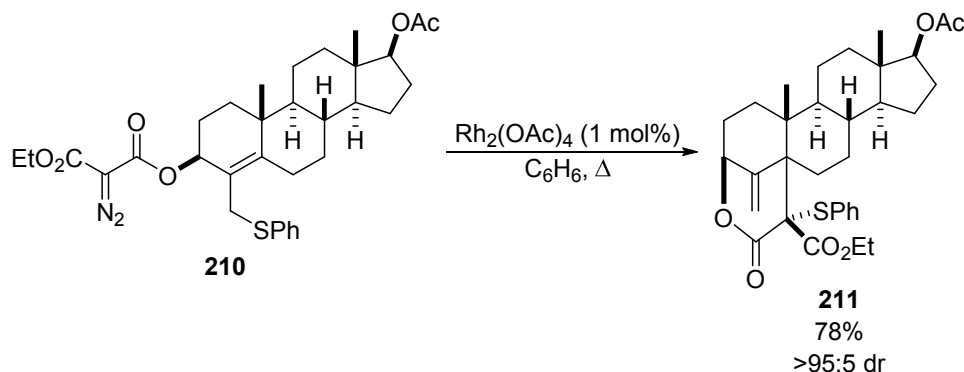

Scheme 51. Synthesis of complex bicyclic  $\delta$ -lactones

The intramolecular [2,3]-rearrangement of cyclic sulfonium ylides can also be used to synthesize substituted cyclohexanone rings with high levels of diastereoselectivity.<sup>99</sup> The method has been demonstrated for the synthesis of functionalized cyclohexanones such as **215** that may be of use for the synthesis of sesquiterpene natural products. The key diazo-tethered allylic sulfide **213** was synthesized through a multi-step linear sequence starting from (*R*)-(+)-limonene **212**.<sup>99b</sup> Catalytic sulfonium ylide formation and [2,3]-rearrangement gave product **214** in 61% yield as a single diastereoisomer (Scheme 52). The phenyl sulfide substituent within **214** could be removed using zinc powder in acetic acid and subsequent decarboxylation gave substituted cyclohexanone **215** in 54% over the two steps. Incorporation of a ring system within the tethered diazoallyl sulfide allows synthetically useful *cis*-fused bicyclic systems such as **217** to be synthesized in high yields with excellent levels of diastereoselectivity (Scheme 52).<sup>100</sup>

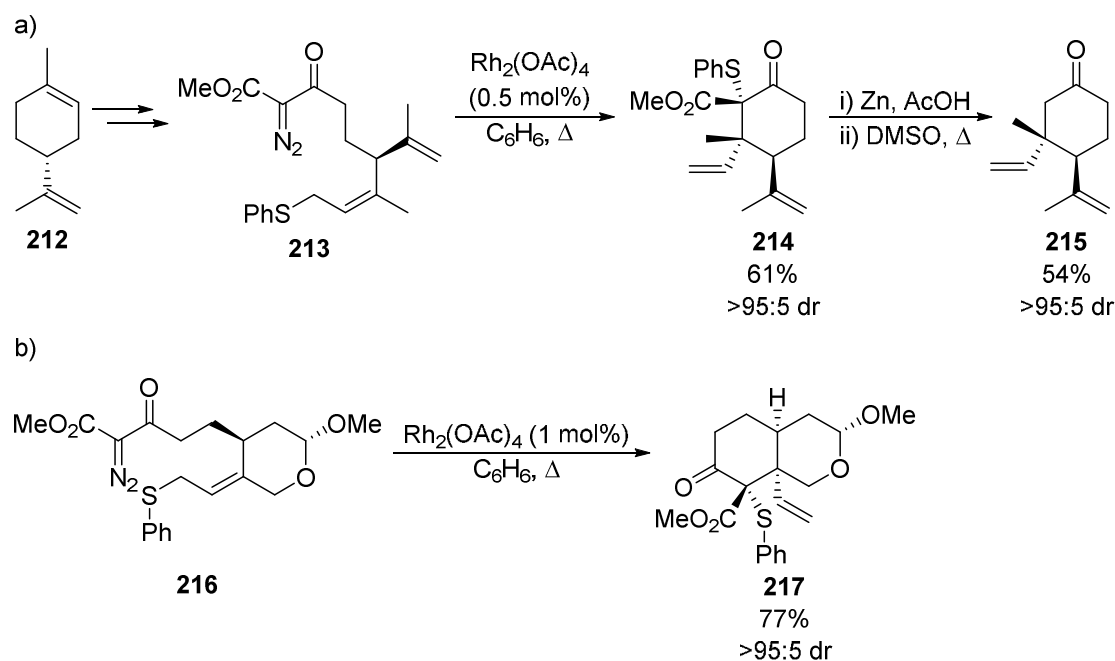

**Scheme 52.** a) Synthesis of substituted cyclohexanone **215** starting from (*R*)-(+)-limonene **212**. b) Synthesis of *cis*-fused bicyclic ring systems



McMills and co-workers have studied the intramolecular [2,3]-rearrangements of sulfonium ylides to form substituted pyrrolizine cores.<sup>101</sup> The reaction of (*Z*)-allylic sulfide **218** is sensitive to both catalyst and solvent, with the direct cyclopropanation of the allylic system to give **220** observed in many cases. However, treating (*Z*)-**218** with catalytic rhodium caprolactamate in fluorobenzene resulted in the highly chemo- and diastereoselective formation of *syn*-pyrrolizine **219** in 60% yield (Scheme 53a). The reaction is stereospecific, with (*E*)-allylic sulfide **221** undergoing catalytic sulfonium ylide formation followed by rearrangement in benzene to give *anti*-pyrrolizine **222** in 71% yield as a single diastereoisomer (Scheme 53b).

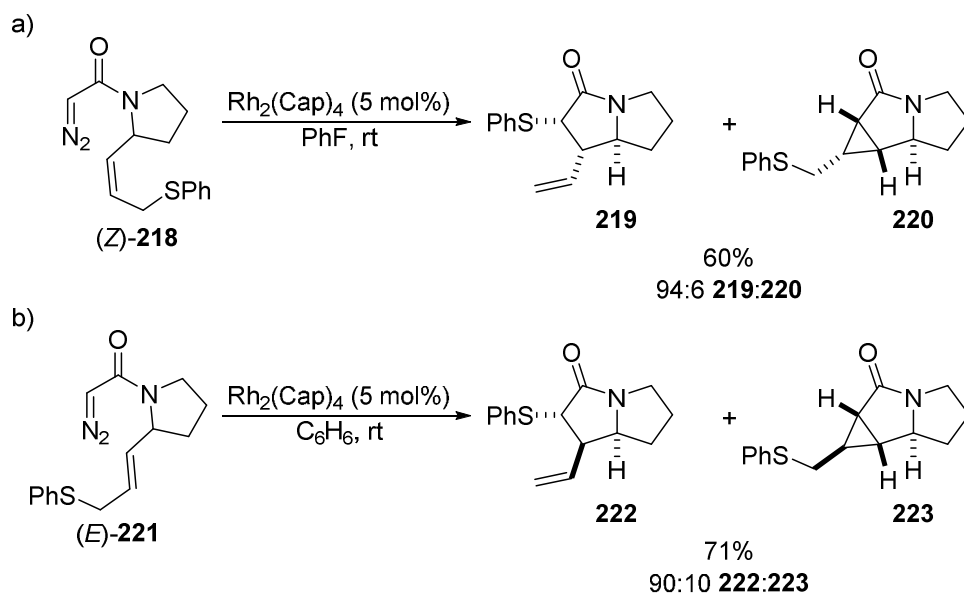

**Scheme 53.** Stereospecific synthesis of substituted pyrrolizine cores. Cap = caprolactamate

Kido and co-workers showed that by altering the position of the allylic sulfide a diastereoselective [2,3]-rearrangement to form spirocyclic products is possible.<sup>102</sup> This method has been exemplified through the synthesis of the enantiomer of sesquiterpene natural product (–)-acorenone B (*ent*-**227**). Starting from commercially available (*S*)-(–)-perillaldehyde **224**, key tethered diazoallylic sulfide **225** was synthesized over 15 steps. Catalytic cyclic sulfonium ylide formation using  $\text{Rh}_2(\text{OAc})_4$  (1 mol%) and [2,3]-

rearrangement gave advanced intermediate **226** in 72% yield as a single diastereoisomer, with only four further steps required to convert **226** into (+)-acorenone B **227** (Scheme 54).<sup>102b</sup>

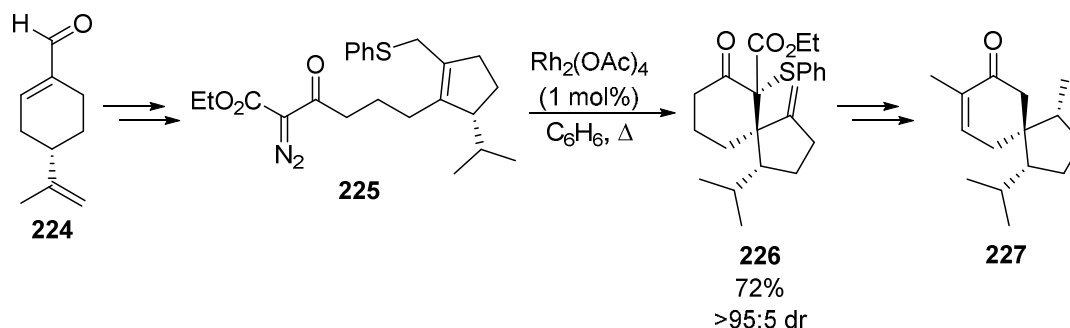

**Scheme 54.** Synthesis of spirocyclic sesquiterpene (+)-acorenone B **227**

Davies and co-workers have reported the use of tethered sulfoxides and alkynes as sulfonium ylide precursors in the presence of either gold or platinum catalysts.<sup>81</sup> For example, allylic sulfoxide **228** undergoes an internal redox reaction in the presence of  $\text{PtCl}_2$  (10 mol%) to form a sulfonium ylide, with subsequent [2,3]-rearrangement forming product **229** in 60% yield and 83:17 dr (Scheme 55). The scope of the reaction was demonstrated for a range of substituted allylic sulfoxides, with the cyclic products generally formed in good yields under either gold or platinum catalysis. The diastereoselectivity of the reaction was better with terminal alkynes, with only moderate levels of diastereoselectivity obtained when substituted alkynes were used.

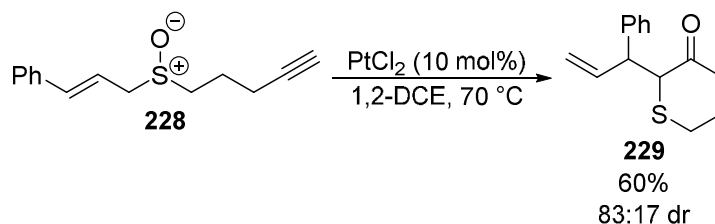

**Scheme 55.** Tethered sulfoxides and alkynes as sulfonium ylide precursors. The relative configuration of the major diastereoisomer is unreported

## 2.4 Halonium ylides

The reaction of metal carbenes with allyl halides and subsequent [2,3]-rearrangement of the resulting halonium ylides has been less widely studied and there are only a few reports of stereoselective variants of this reaction. An early diastereoselective example of such a process was reported in 1980 by Thomas and co-workers. Catalytic decomposition of diazopenicillanate **151** with  $\text{Cu}(\text{acac})_2$  (11 mol%) in the presence of excess allyl bromide **230** gave rearranged product **231** in 48% yield as a single diastereoisomer (Scheme 56), however product **231** was unstable and more readily characterized after dehalogenation using tributyl tin hydride.<sup>65</sup>

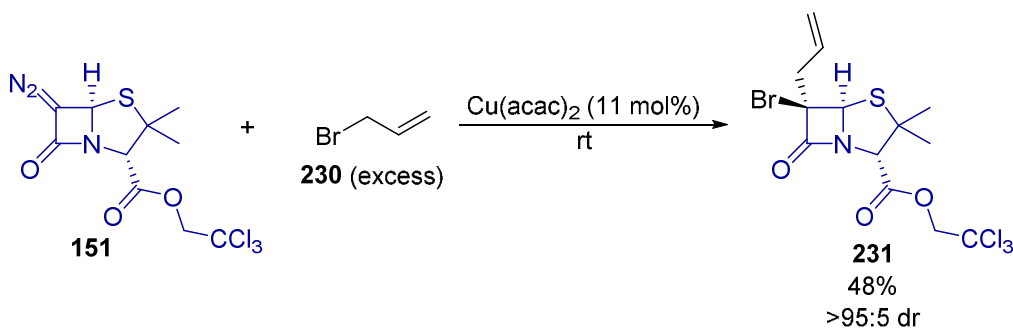

**Scheme 56.** Catalytic halonium ylide formation from diazopenicillanate **151**

Doyle and co-workers investigated the reaction of ethyl diazoacetate **20** with allyl halides using rhodium-based catalysts.<sup>51</sup> The major reaction product obtained was dependent on the allyl halide used. For example both allyl chloride and allyl bromide predominantly gave cyclopropanation in the reaction with  $\text{Rh}_2(\text{OAc})_4$ , whereas allyl iodide led to halonium ylide formation and [2,3]-rearrangement into **233** (Scheme 57). The reaction of ethyl diazoacetate **20** with crotyl bromide using either copper or rhodium catalysis led to a mixture of products from [2,3]-rearrangement, [1,2]-rearrangement, and cyclopropanation and in all cases essentially no diastereoselectivity was observed for the [2,3]-rearrangement product.

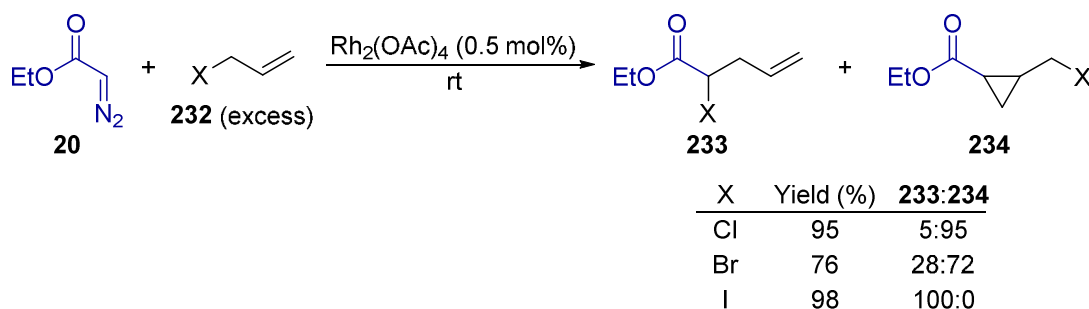

**Scheme 57.** Effect of the allyl halide on product selectivity in the reaction with ethyl diazoacetate **20**

16  
17  
18  
19  
20  
21  
22  
23  
24  
25  
26  
27

The reaction of ethyl diazoacetate **20** with substituted allyl bromide and chlorides has subsequently been investigated using catalytic silver (I) complexes<sup>103</sup> and ruthenium porphyrin<sup>104</sup> complexes. In these cases the desired [2,3]-rearranged products were obtained in high yields, but unfortunately the products were formed as a 50:50 mixture of diastereoisomers in all cases.

28  
29  
30  
31  
32  
33  
34  
35  
36  
37  
38  
39  
40  
41  
42  
43  
44

In 1998, Doyle and co-workers reported the first enantioselective halonium ylide rearrangement.<sup>8</sup> The reaction of ethyl diazoacetate **20** with allyl iodide **235** catalyzed by a variety of chiral dirhodium carboxamides gave [2,3]-rearrangement product **236** in low yields and poor enantioselectivity, with products of carbene dimerization also observed in many cases. However, use of catalytic copper complexed with BOX ligand **121** led to selective [2,3]-rearrangement, forming product **236** in 62% yield and a promising 69% ee (Scheme 58).

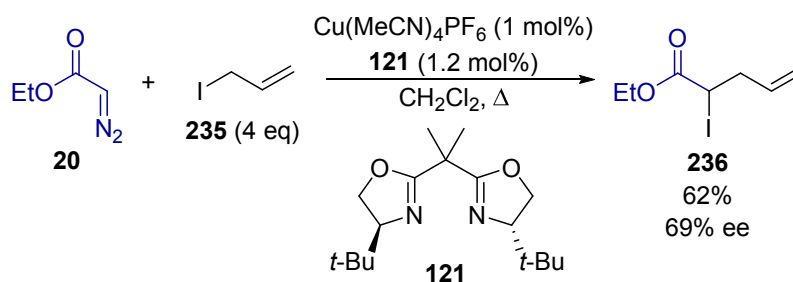

**Scheme 58.** First example of an enantioselective halonium rearrangement. The absolute configuration of the product is unreported

1  
2  
3  
4  
5  
6  
7  
8  
9  
10  
11  
12  
13  
14  
15  
16  
17  
18  
19  
20  
21  
22  
23  
24  
25  
26  
27  
28  
29  
30  
31  
32  
33  
34  
35  
36  
37  
38  
39  
40  
41  
42  
43  
44  
45  
46  
47  
48  
49  
50  
51  
52  
53  
54  
55  
56  
57  
58  
59  
60

1  
2  
3 The use of dirhodium complexes with fluorinated chiral carboxamide ligands has also been  
4 investigated in this process.<sup>105</sup> In this case, competing cyclopropanation was observed and the  
5 [2,3]-rearrangement product **236** was only obtained in modest yields with low levels of  
6 enantioselectivity.  
7  
8  
9  
10

### 11 12 13 14 **3. [2,3]-REARRANGEMENTS OF AMMONIUM YLIDES FROM ALLYLIC** 15 16 **QUATERNARY AMMONIUM SALTS**

17  
18 In 2011, Tambar and co-workers reported an alternative strategy to avoid the use of diazo  
19 compounds in catalytic [2,3]-rearrangements of allylic ammonium ylides.<sup>106</sup> The  
20 methodology makes use of the palladium-catalyzed allylic substitution of allylic carbonates  
21 **237** with tertiary amino esters **239** (Scheme 59a). The resulting quaternary ammonium salt  
22 **240** undergoes rapid deprotonation into ammonium ylides **241** and subsequent [2,3]-  
23 rearrangement to generate  $\alpha$ -amino ester products **242**. Optimization of the catalyst system  
24 revealed that Pd<sub>2</sub>dba<sub>3</sub>·CHCl<sub>3</sub> in combination with electron-deficient P(2-furyl)<sub>3</sub> ligand gave  
25 the desired products in high yields with good levels of diastereoselectivity (Scheme 59b). The  
26 reaction was applicable to a range of aryl, heteroaryl and alkyl substituted allylic carbonates  
27 **244** alongside various substituted  $\alpha$ -amino esters or  $\alpha$ -amino ketones to form the  
28 corresponding *anti*-[2,3]-rearrangement products **245** in uniformly good yield and high  
29 diastereoselectivity in most cases. The observed *anti*-diastereoselectivity is proposed to be  
30 due to an *exo*-transition state during the [2,3]-rearrangement step.  $\alpha$ -Amino sulfonimide **246**  
31 bearing Oppolzer's camphor sultam auxiliary could also be utilized in this process, forming  
32 enantiomerically enriched  $\alpha$ -amino acid derivatives such as **248** in excellent yield and high dr  
33 (Scheme 59c).  
34  
35  
36  
37  
38  
39  
40  
41  
42  
43  
44  
45  
46  
47  
48  
49  
50  
51  
52  
53  
54  
55  
56  
57  
58  
59  
60

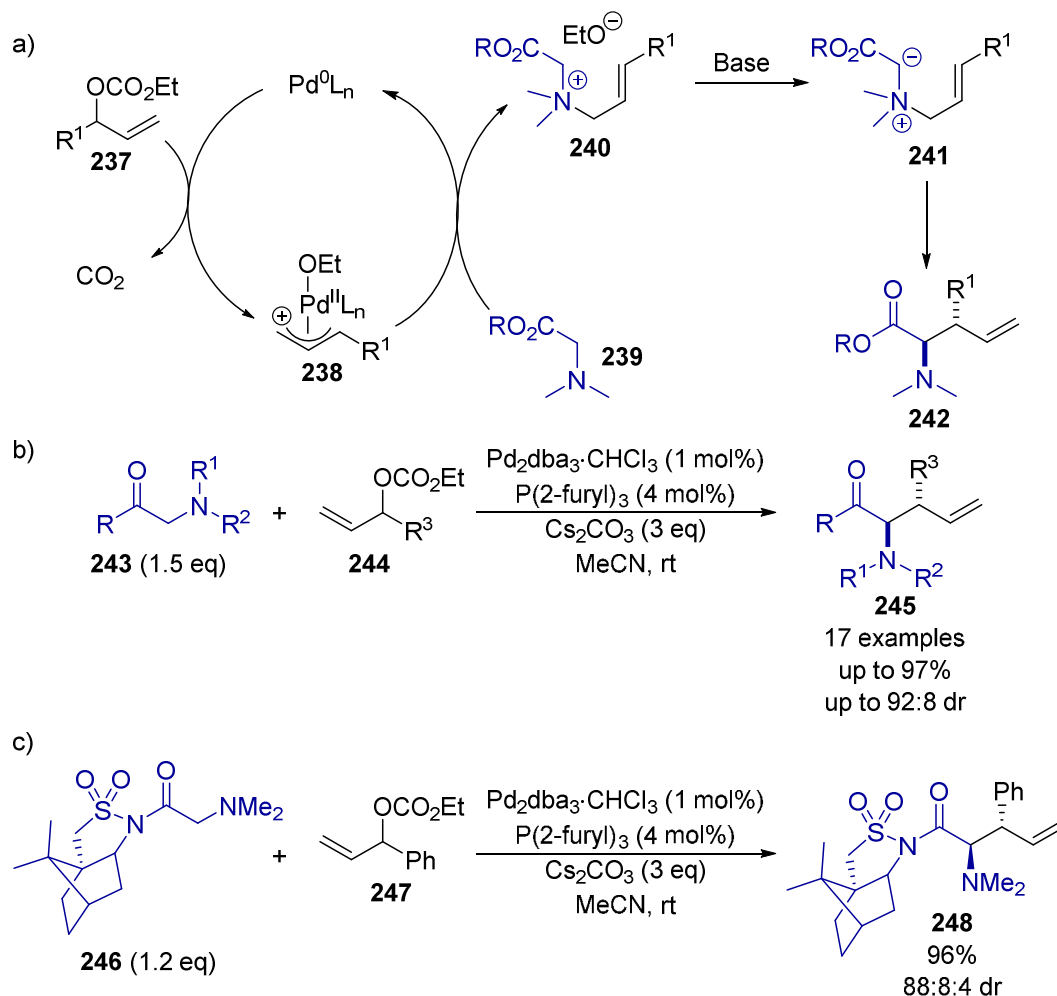

**Scheme 59.** Palladium-catalyzed allylic amination to form [2,3]-rearrangement precursors

This methodology was subsequently applied to the formal total synthesis of the marine alkaloid ( $\pm$ )-amathaspiramide F (**253**).<sup>107</sup> Reacting proline derivative **249** under the previously optimized conditions with the allylic carbonate bearing the functionalized aryl ring found within amathaspiramide F (**253**) unexpectedly led to the preferential formation of undesired diastereoisomer **252** in 75% yield (Scheme 60). Further investigation on a simplified system revealed that the presence of an *ortho*-substituent within the aryl allylic carbonate led to a significant reduction in previously observed *anti*-diastereoselectivity. In light of this, the synthetic route was modified and the key ammonium salt formation-[2,3]-rearrangement step was performed using MOM-protected aryl carbonate, resulting in

preferential formation of the desired diastereoisomer **251** in 70% yield. Further manipulation of **251** gave an advanced intermediate in the formal total synthesis of (±)-amathaspiramide F (**253**). Although proline ester **249** was enantiomerically pure, the resulting [2,3]-rearrangement products **251** and **252** were racemic showing that the stereochemical information within **249** is lost during the allylic amination.

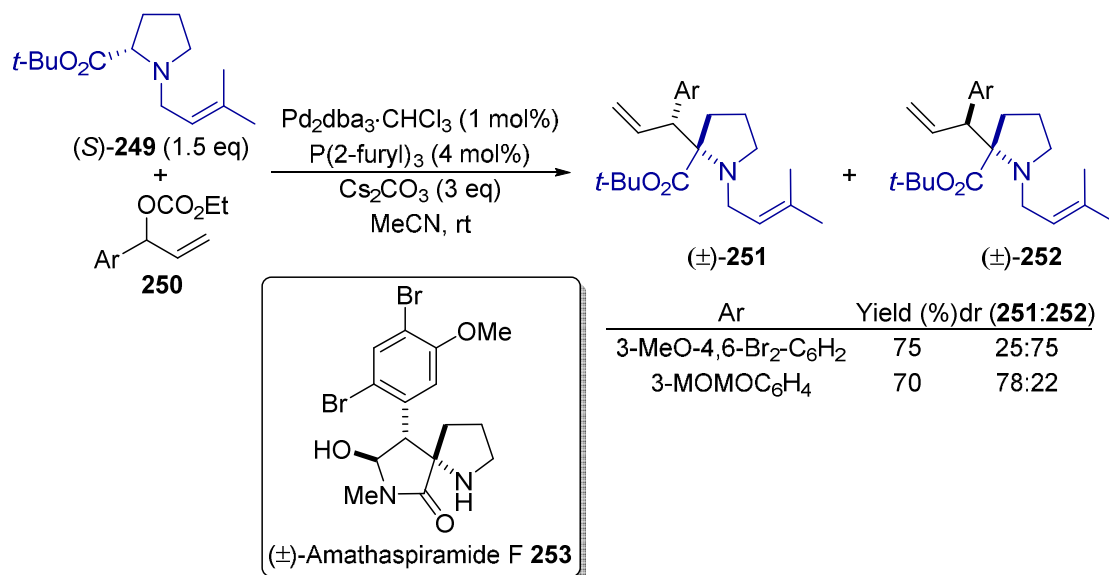

**Scheme 60.** Switch in diastereoselectivity observed *en route* to the formal synthesis of (±)-amathaspiramide F (**253**)

Tambar and co-workers reported the diastereoselective synthesis of cyclic  $\alpha$ -amino acid derivatives through a tandem allylic amination-[2,3]-rearrangement followed by ring-closing metathesis.<sup>108</sup> For example, reacting homoallyl amino ester **254** with allylic carbonate **255** under the previously optimized conditions followed by ring-closing metathesis of the intermediate [2,3]-rearrangement product using Hoveyda-Grubbs II gave cyclic  $\alpha$ -amino acid **256** in 85% yield and 89:11 dr (Scheme 61). The methodology was applied to a range of aryl and alkyl substituted allylic carbonates, forming the cyclic products in generally good yields and high diastereoselectivity over the two steps. An enantiomerically pure cyclic  $\alpha$ -amino acid was also accessible using a homoallyl  $\alpha$ -amino acid derivative bearing Oppolzer's camphorsultam auxiliary as the starting material.

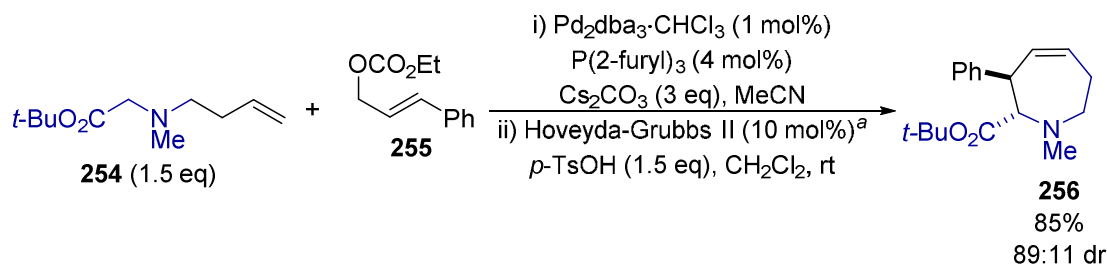

**Scheme 61.** Diastereoselective cyclic  $\alpha$ -amino ester synthesis. <sup>a</sup>Catalyst added in two portions

In 2014, Smith and co-workers reported the first organocatalytic stereoselective [2,3]-rearrangement of allylic ammonium salts **259**, which were either isolated or made *in situ* from *p*-nitrophenyl bromoacetate **257** and an allylic amine **258**.<sup>109</sup> Reacting allylic ammonium salts **259** with the isothioureia catalyst (*R*)-BTM **260** (20 mol%) and HOBT (20 mol%) as a co-catalyst in the presence of a mild base promoted a stereoselective [2,3]-rearrangement, with a nucleophilic quench giving *syn*- $\alpha$ -amino acid derivatives **261** in high yield and excellent stereocontrol (Scheme 62a). The reaction scope was demonstrated for a range of amine substituents and vinylic aryl groups alongside a number of different amine and alcohol nucleophiles for the quench, giving access to functionalized  $\alpha$ -amino acid derivatives with excellent diastereo- and enantioselectivity. The proposed mechanism involves *N*-acylation of (*R*)-BTM **260** with allylic ammonium salt **259** to form dicationic species **262**, with deprotonation forming ammonium ylide **263** (Scheme 62b). Stereoselective [2,3]-rearrangement of **263** generates acyl ammonium **264**, which can be intercepted by either the HOBT **265** co-catalyst to form **266** or directly by *p*-nitrophenoxide to form ester **267**. Nucleophilic quench of **267** displaces *p*-nitrophenol to give readily isolable  $\alpha$ -amino acid derivatives **261**. The high levels of stereocontrol observed can be rationalized by *endo*-type pre-transition state assembly **TS-263** (Scheme 62c). Stabilizing interactions between the lone pair of the oxygen atom  $n_o$  and the  $\sigma^*_{\text{C-S}}$  help to lock the conformation of *N*-acyl ammonium **263**, while the stereodirecting phenyl substituent adopts a pseudoaxial position to minimize 1,2-steric interactions. Rearrangement occurs preferentially opposite to the stereodirecting



group, with a favorable  $\pi$ -cation interaction between the allylic C(3)-aryl substituent and the acyl ammonium thought to be a requirement for high stereocontrol.

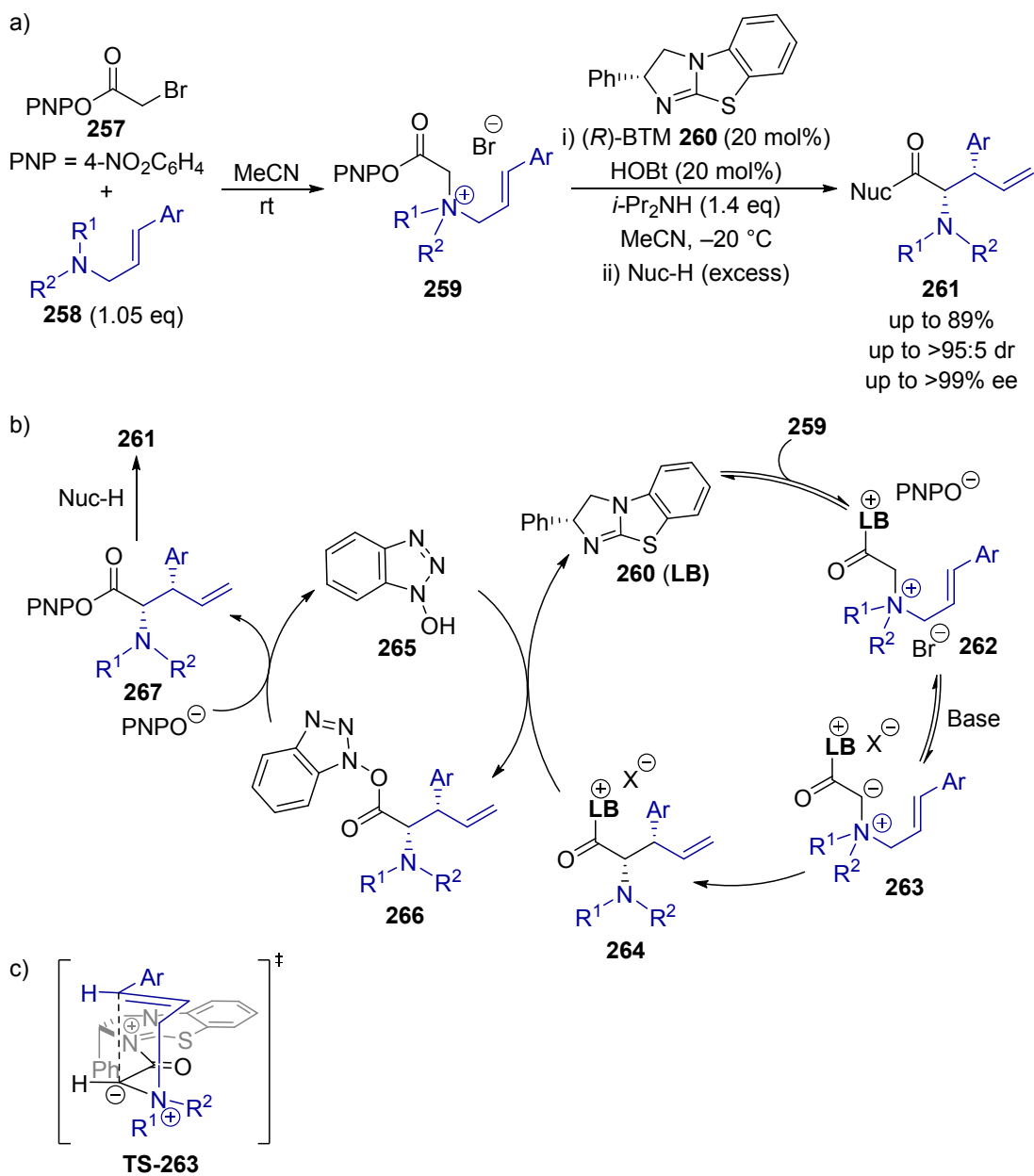

Scheme 62. Organocatalytic stereoselective [2,3]-rearrangement of allylic ammonium salts

#### 4. [2,3]-REARRANGEMENT OF O-PROPARGYLIC OXIMES

Nakamura and co-workers have extensively studied the transition metal-catalyzed [2,3]-rearrangement of *O*-propargylic oximes **268** (Scheme 63). The resulting *N*-allenyl nitrones **269** undergo a variety of further transformations into different products depending on the specific substrate utilized and the reaction conditions. *N*-Allenyl nitrones had received little attention previously due to their inherent instability, therefore *in situ* generation through [2,3]-rearrangement provides an effective method of investigating the reactivity of these intermediates in a variety of cascade processes. Although the *N*-allenyl nitronone intermediates are formal [2,3]-rearrangement products, it is possible that in many cases their formation proceeds through alternative metal-mediated pathways and therefore the reactions may not be true pericyclic processes.

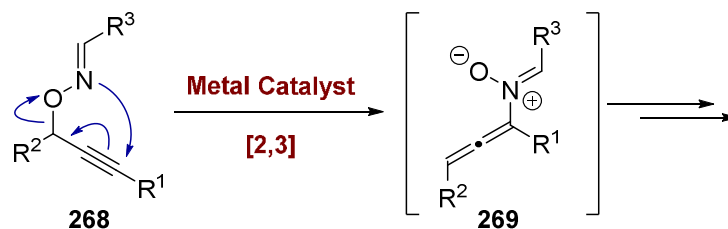

Scheme 63. [2,3]-Rearrangement of *O*-propargylic oximes

##### 4.1 Synthesis of pyridine *N*-oxides and four-membered cyclic nitrones

Nakamura and co-workers first reported the copper-catalyzed [2,3]-rearrangement of (*E*)-*O*-propargylic  $\alpha,\beta$ -unsaturated aldoximes such as **270** for the synthesis of pyridine *N*-oxides (Scheme 64a).<sup>110</sup> The initially formed [2,3]-rearrangement product **271** undergoes a  $6\pi$ -electrocyclization followed by tautomerization to form pyridine *N*-oxide **272** in 70% yield. However, the reaction of (*Z*)-**273** gave cyclic nitronone **275** in 84% yield and excellent *E:Z* selectivity, with intermediate **274** undergoing preferential  $4\pi$ -electrocyclization followed by isomerization *via* an allyl cation into the observed product (Scheme 64b). Nitronone **275** could

also be thermally isomerized into a 2,3,6-trisubstituted pyridine *N*-oxide by heating in DMF at 180 °C.<sup>111</sup>

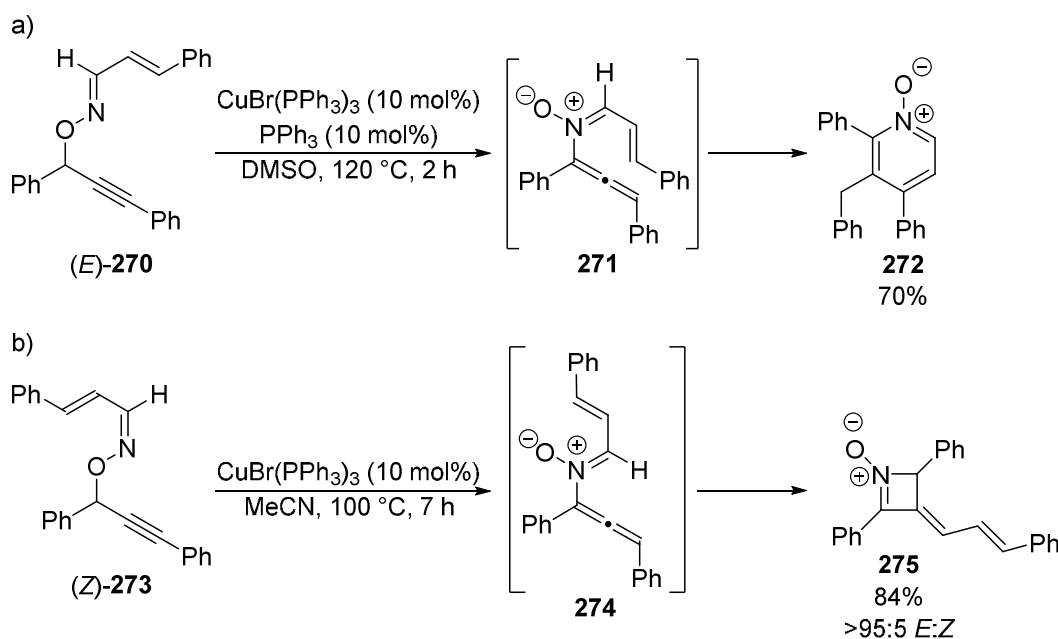

**Scheme 64.** Differential reactivity of (*E*)-**270** and (*Z*)-**273**

The stereoselective formation of cyclic nitrones was subsequently studied in more detail using aryl aldoximes.<sup>112</sup> Reacting oxime **276** with  $[\text{CuCl}(\text{cod})_2]$  (5 mol%) in MeCN at 70 °C led to the regioselective formation of nitrone **277** in 86% yield as a 73:27 *E:Z* mixture (Scheme 65). In this case the *E:Z* geometry of the aldoxime was not important, with both reacting to give nitrone **277** with similar levels of selectivity. The reaction was applicable to a range of propargylic aryl and alkyl substituents, forming the corresponding nitrones in high yields and with reasonable *E:Z* selectivity obtained in most cases. Mechanistically, the copper is thought to activate the alkyne towards [2,3]-rearrangement, with the resulting *N*-allenyl nitrone undergoing a  $4\pi$ -electrocyclization into the observed product. At high temperature, the minor (*Z*)-isomer of **277** can undergo thermal isomerization into both (*E*)-**277** and regioisomer **278** whereas (*E*)-**277** is stable at high temperature.

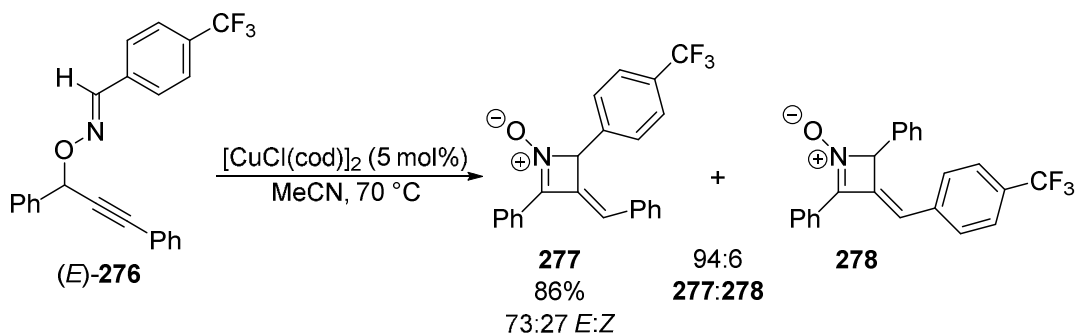

Scheme 65. Copper-catalyzed rearrangement of *O*-propargylic aryl aldoximes

14  
15  
16  
17  
18  
19  
20  
21  
22  
23  
24  
25  
26  
27  
28  
29  
30  
31  
32  
33  
34  
35  
36  
37  
38  
39  
40  
41  
42  
43  
44  
45  
46  
47  
48  
49  
50  
51  
52  
53  
54  
55  
56  
57  
58  
59  
60

Subsequently it was reported that the outcome of the reaction using alkyl propargylic substituents is highly dependent on the electronic nature of the aryl oxime substituent (Scheme 66).<sup>113</sup> For example, reacting (*E*)-oxime **279** bearing an electron-deficient 3,5-Br<sub>2</sub>C<sub>6</sub>H<sub>3</sub> substituent with CuCl (10 mol%) led to exclusive formation of cyclic nitrone **280**. However, 4-ClC<sub>6</sub>H<sub>3</sub> substituted oxime **279** gave a 60:30 mixture of nitrone **280** and amidodiene **281** and introduction of a strongly electron-donating 4-Me<sub>2</sub>NC<sub>6</sub>H<sub>4</sub> group led to selective formation of the corresponding amidodiene **281** in 87% yield. This process was general for electron-rich aryl oxime substituents and could tolerate various propargylic alkyl groups, forming amidodiene products with high levels of selectivity in good yield. It is postulated that the presence of an electron-rich aryl oxime substituent alters the mechanism of the reaction after the copper-catalyzed rearrangement of the *O*-propargylic oxime. In this case, the *N*-allenyl nitrone intermediate is thought to undergo selective oxaziridine formation instead of 4π-electrocyclization. A 1,2-hydrogen shift followed by copper-catalyzed isomerization of the allene leads to the observed amidodiene products.

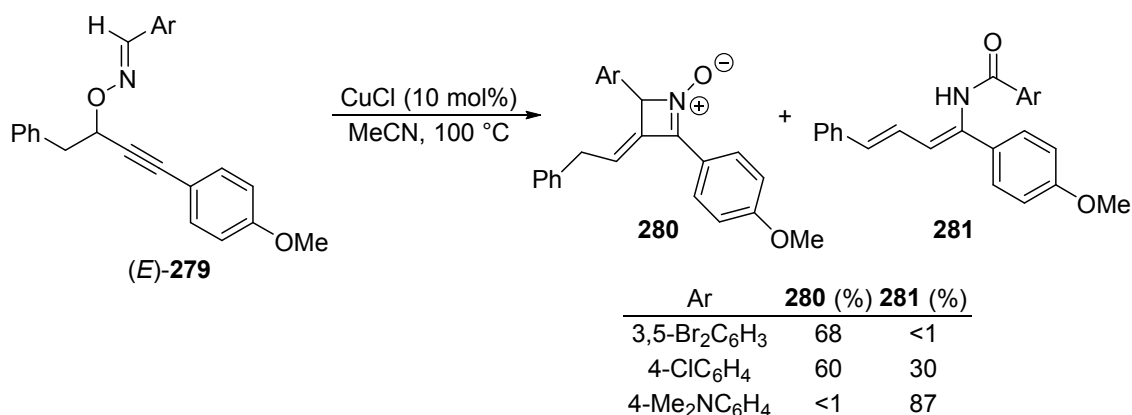

Scheme 66. Effect of the aryl oxime substituent on the rearrangement

#### 4.2 Synthesis of seven- and eight-membered rings

Nakamura and co-workers further explored the utility of *O*-propargylic oximes in tandem rhodium-catalyzed [2,3]-rearrangement-heterocyclization processes to form azepine and azocine *N*-oxide derivatives. For example, treating (*Z*)-*O*-propargylic cyclopropylcarbaldoxime **282** with [RhCl(cod)]<sub>2</sub> (2.5 mol%) and sodium diphenylphosphinobenzene-3-sulfonate (tppms, 18 mol%) gave (*Z*)-azepine *N*-oxide **283** in 92% yield (Scheme 67a).<sup>114</sup> Water soluble tppms was used as the ligand to avoid difficulties encountered in separating **283** from triphenylphosphine oxide. The reaction works well for a range of aryl substituents, but the presence of alkyl substituents on either the propargylic carbon or the alkyne led to longer reaction times and lower yields. The rhodium-catalyzed rearrangement of the corresponding (*E*)-*O*-propargylic cyclopropylcarbaldoximes exclusively gave the (*Z*)-azepine *N*-oxide products. However, the reactions using (*E*)-oximes were much more sensitive to the amount of ligand used and generally gave lower yields than the reaction using the corresponding (*Z*)-oxime.

This methodology was extended to the synthesis of azocine *N*-oxides using (*E*)-*O*-propargylic cyclobutylcarbaldoxime as substrates.<sup>115</sup> For example, the rhodium-catalyzed reaction of (*E*)-**284** gave (*Z*)-azocine *N*-oxide **285** in 93% yield with complete control of the alkene geometry

(Scheme 67b). A number of aryl substituents was tolerated in this process, but propargylic alkyl substituents gave the products in lower yields and the use of a terminal alkyne gave a complex mixture. The tandem [2,3]-rearrangement-metallacyclization of enantiomerically pure (*E*)-oxime **286** gave (*Z*)-azocine *N*-oxide **287** in 87% yield and 74% ee, showing reasonably high levels of chirality transfer through the axially chiral *N*-allenyl nitron intermediate (Scheme 67c).

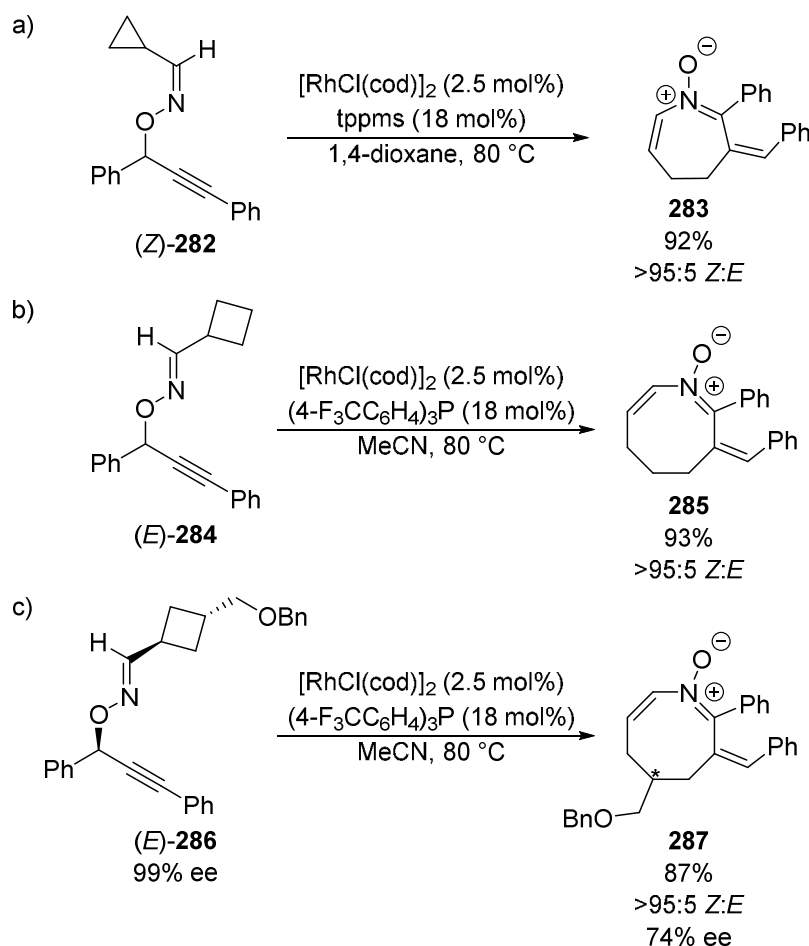

**Scheme 67.** [2,3]-Rearrangement of a) *O*-propargylic cyclopropyl- and b) cyclobutylcarbaldoximes. c) Chirality transfer in the [2,3]-rearrangement of cyclobutylcarbaldoximes. The absolute configuration of the major enantiomer of **287** was unreported. tppms = sodium diphenylphosphinobenzene-3-sulfonate

A simplified mechanistic proposal for the tandem [2,3]-rearrangement-heterocyclization reaction is shown in Scheme 68.<sup>114-115</sup> Coordination of the rhodium catalyst to (*Z*)-*O*-propargylic oxime **282** promotes rearrangement into  $\eta^4$ -coordinated *N*-allenyl nitron **289**.

While this step represents a formal [2,3]-rearrangement, it may proceed stepwise *via* a cyclic vinyl rhodium species. Metallacyclization of **289** gives aza-rhodacycle **290**, which undergoes ring-expansion through cleavage of the least hindered cyclopropane bond to form eight-membered aza-rhodacyclic **291**, with subsequent reductive elimination of the rhodium giving product **283**.

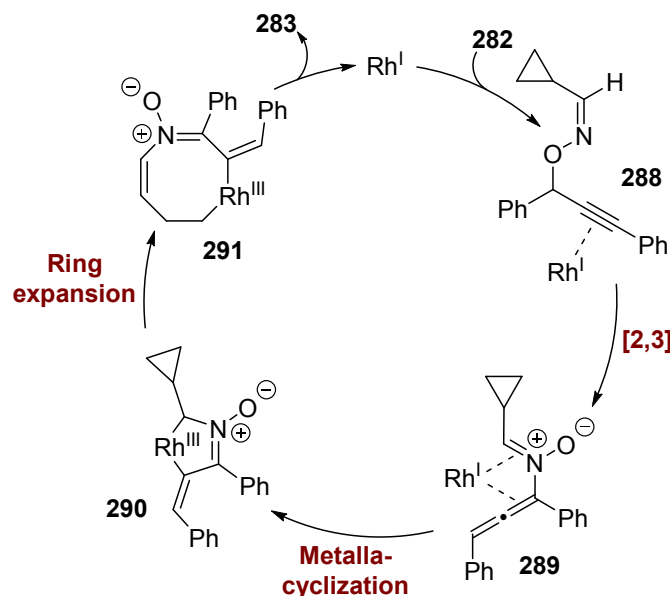

**Scheme 68.** Proposed mechanism for the tandem [2,3]-rearrangement and heterocyclization of **282**

Alternative cascade processes using the *N*-allenyl nitrono intermediates generated from [2,3]-rearrangement of *O*-propargylic aldoximes as a 1,3-dipolar reagents have also been investigated.<sup>116</sup> Treating (*Z*)-*O*-propargylic aldoxime **292** and *N*-phenylmaleimide **293** with  $[\text{CuCl}(\text{cod})]_2$  (5 mol%) promotes a cascade sequence involving [2,3]-rearrangement, [3+2] cycloaddition, and [1,3]-oxygen migration to form oxazepine derivative **294** in 71% yield as a single diastereoisomer (Scheme 69). The [3+2]-cycloaddition between the intermediate nitrono and *N*-phenylmaleimide **293** is thought to be highly *exo*-selective, accounting for the high levels of diastereoselectivity. The reaction scope was demonstrated for various aryl and alkyl substituted *O*-propargylic formaldoximes, giving the oxazepine products in good yields.

Alternative dipolarophiles including various *N*-substituted maleimides and fumaric acid esters were also tolerated.

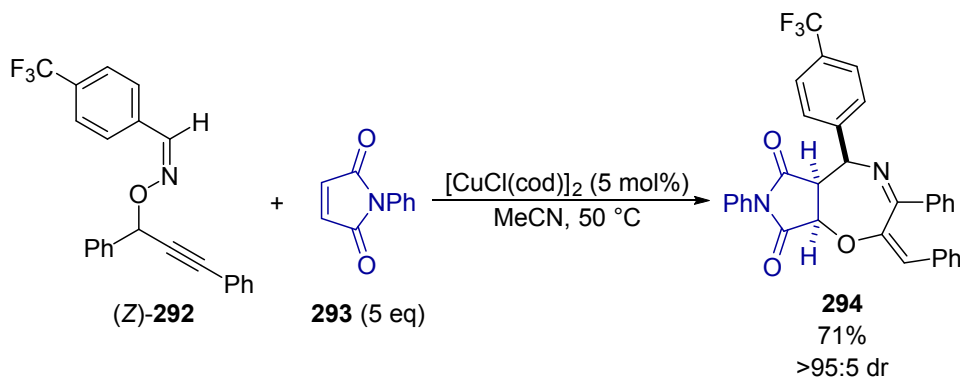

Scheme 69. Copper-catalyzed cascade to form substituted oxazepines

## 5. [2,3]-REARRANGEMENT OF ALLYLIC SULFOXIDES, SELENOXIDES, SULFIMIDES, AND *N*-OXIDES

### 5.1 Catalytic [2,3]-Rearrangement of Allylic Sulfoxides and Selenoxides

The [2,3]-rearrangement of allylic sulfoxides (Mislow-Evans rearrangement) into allylic alcohols has found a number of uses in organic synthesis. The reaction is stereospecific as any stereochemistry on sulfur can be transferred onto carbon during the rearrangement.<sup>3</sup> Given the potential synthetic utility of this reaction, it is perhaps surprising that relatively few stereoselective catalytic procedures have been developed.

Hilvert and co-workers reported one of the first stereoselective catalytic [2,3]-rearrangements of a single allylic sulfoxide using catalytic antibodies. Although significant rate-enhancement over the background rearrangement was observed, the resulting allylic alcohol was only obtained in modest enantioselectivity (40% ee).<sup>117</sup>

Hagiwara and co-workers reported a tandem Knoevenagel condensation-[2,3]-rearrangement reaction catalyzed by silica-supported nitrogen base **297** (50 mol%).<sup>118</sup> The catalytic Knoevenagel reaction between a range of substituted aldehydes and aryl sulfinylacetone nitrile



296 gave intermediate 298, which underwent isomerization into an allylic sulfoxide followed by [2,3]-rearrangement under the reaction conditions. Addition of diethylamine promoted hydrolysis of the resulting sulfinate ester into allylic alcohol 299 (Scheme 70). A range of substituted aldehydes could be used, selectively forming the (*E*)-allylic alcohol products in reasonable yields with excellent *E:Z* selectivity. When (*R*)-(+)-citronellal was used the resulting allylic alcohol was formed in 50:50 dr, with the stereocenter within the aldehyde having no influence on the diastereoselectivity of the [2,3]-rearrangement.

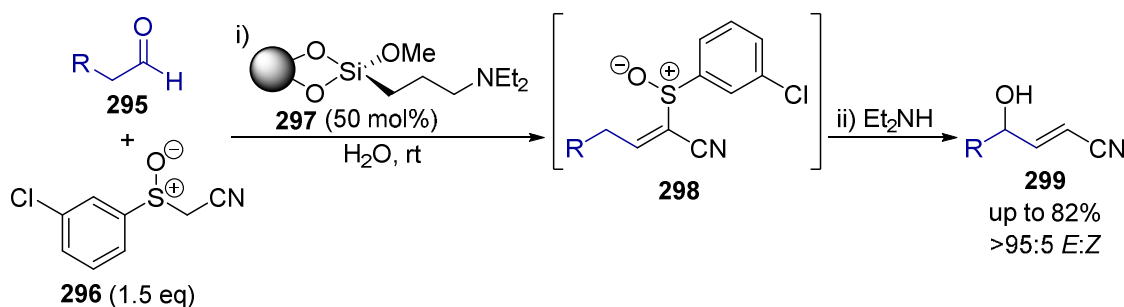

**Scheme 70.** Tandem Knoevenagel condensation-[2,3]-rearrangement promoted by silica supported base 297

Miura and co-workers have reported a stereoselective organocatalytic [2,3]-rearrangement of  $\alpha$ -sulfinyl enones.<sup>119</sup> Treating enantiomerically pure enone 300 with catalytic DBU (10 mol%) in the presence of an excess of triphenyl phosphine promotes isomerization into an allylic sulfoxide, which spontaneously undergoes a stereoselective [2,3]-rearrangement. Quenching the reaction with aqueous hydrogen peroxide to hydrolyze the initially formed sulfinyl ester was optimal, forming allylic alcohol 301 in 77% yield and 99% ee (Scheme 71). The reaction was applicable to a range of alkyl and aryl substituted enones, with the allylic alcohol products formed in good yield. In the majority of cases the configuration of the enantiomerically enriched  $\alpha$ -sulfinyl enone was efficiently transferred into the corresponding allylic alcohol.

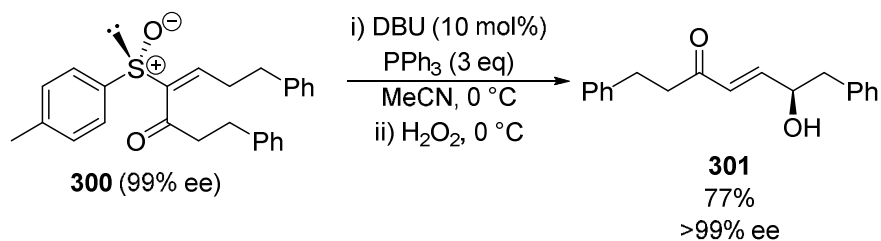

**Scheme 71.** Organocatalytic [2,3]-rearrangement of  $\alpha$ -sulfinyl enones. DBU = 1,8-diazabicyclo[5.4.0]-undec-7-ene

11  
12  
13  
14  
15  
16  
17  
18  
19  
20  
21  
22  
23  
24  
25  
26  
27

Diastereoselective allylic oxidation reactions using selenium dioxide (Riley oxidation) have also been utilized in organic synthesis, for example in one of the final steps in Corey's first total synthesis of Miroestrol.<sup>120</sup> The oxidation can be rendered catalytic in SeO<sub>2</sub> by using an excess of a suitable oxidant, such as hydrogen peroxide. The reaction is thought to proceed through an ene reaction between the allylic system and SeO<sub>2</sub>, followed by [2,3]-rearrangement of the intermediate seleninic acid **303** (Scheme 72).

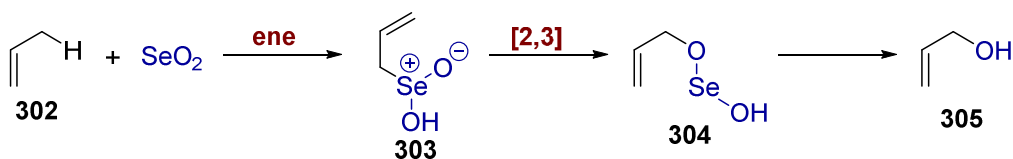

**Scheme 72.** Allylic oxidation using selenium dioxide

35  
36  
37  
38  
39  
40  
41  
42  
43  
44  
45  
46  
47  
48

Paquette and Lobben used a catalytic diastereoselective Riley oxidation in the synthesis of cyclohexanone **308**, which was used as a substrate for investigating the facial selectivity of indium promoted allylations of various 2-hydroxycyclohexanone (Scheme 73).<sup>121</sup> Treating *exo*-methylene cyclohexane **306** with catalytic SeO<sub>2</sub> (5 mol%) and an equivalent of *t*-butyl hydroperoxide gave allylic alcohol **307** in 75% yield as a single diastereoisomer.

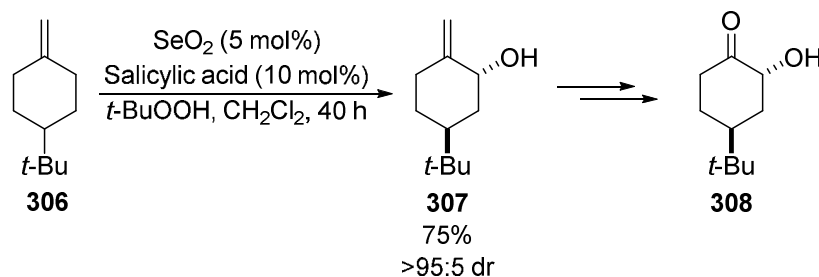

## Scheme 73. Catalytic diastereoselective Riley oxidation

Carter and co-workers reported the first catalytic oxidation of prochiral allylic selenides and tandem [2,3]-rearrangement.<sup>122</sup> Vanadyl acetylacetonate (10 mol%) in the presence of cumene hydroperoxide **310** promoted the tandem oxidation and [2,3]-rearrangement of a small range of allylic selenides. Addition of tributyl phosphine efficiently cleaved the initially formed selenate to give a range of allylic alcohols in good yield. However, initial attempts to perform the reaction stereoselectivity by introducing a remote stereocenter were unsuccessful, with allylic selenide **309** reacting to give allylic alcohol **311** as a mixture of diastereoisomers (Scheme 74a). Further attempts to induce stereochemical control over this tandem process using chiral ligands for the vanadium were also unsuccessful.<sup>123</sup> However, introduction of an oxazole-based auxiliary onto allylic selenide **312** resulted in a more diastereoselective rearrangement, with allylic alcohol **313** obtained in good enantioselectivity after cleavage of the selenate (Scheme 74b).

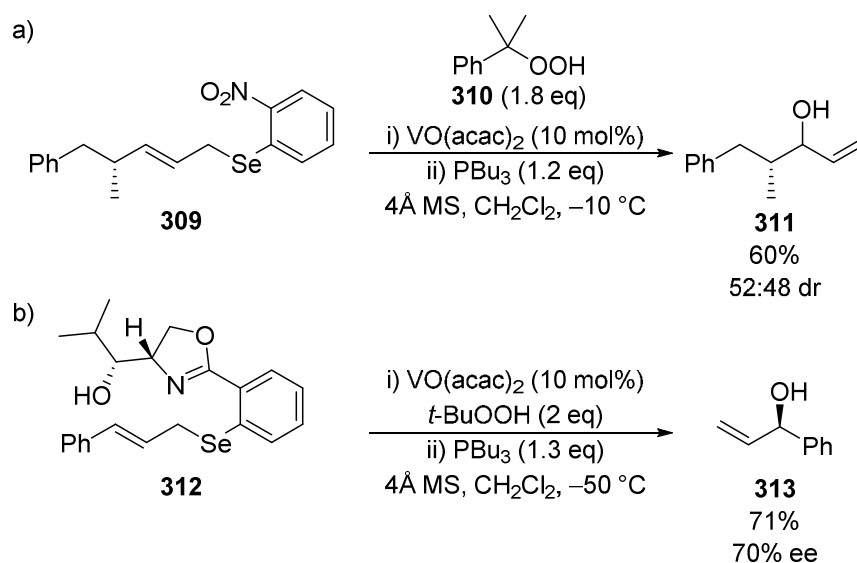

Scheme 74. Vanadium-catalyzed tandem oxidation and [2,3]-rearrangement

## 5.2 Catalytic [2,3]-Rearrangement of Allylic Sulfimides

Sharpless first reported that sulfur diimide species react with alkenes in a similar way to selenium dioxide, undergoing an ene reaction into an intermediate sulfimide (the nitrogen analogue of a sulfoxide) followed by [2,3]-rearrangement into an allylic amine.<sup>124</sup> For many years this process was thought to be incompatible with enantioselective catalysis due to the facile nature of the thermal [2,3]-rearrangement of sulfimides without a catalyst.<sup>3</sup>

However, in 1996 Uemura and co-workers reported the first enantioselective copper-catalyzed sulfimidation using *N*-tosyliminobenzylidene **314** as a nitrene source.<sup>125</sup> Applying these conditions to allylic sulfides resulted in sulfimidation followed by [2,3]-rearrangement to afford sulfonamides, with no competing aziridination observed. For example, treating allylic sulfide **315** with **314** in the presence of CuOTf (5 mol%) and BOX ligand **316** (6 mol%) gave sulfonamide **317** in 80% yield and 58% ee (Scheme 75). This methodology was applied to a small range of substituted allylic sulfides, with the corresponding sulfonamides formed in only moderate yields and low enantioselectivity. The same conditions were also applied to the catalytic [2,3]-rearrangement of allylic selenides, but lower levels of enantioselectivity were obtained.<sup>126</sup>

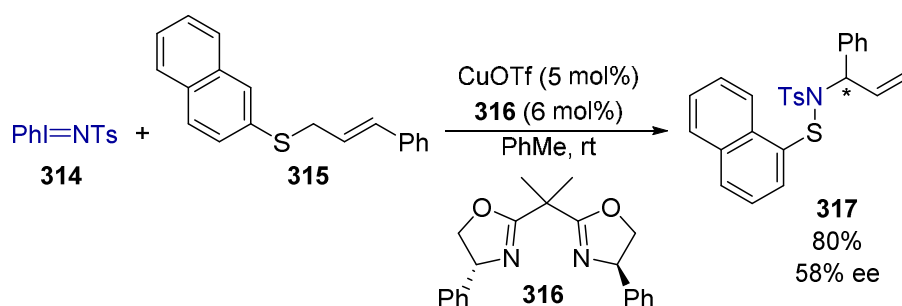

**Scheme 75.** Enantioselective sulfimidation followed by [2,3]-rearrangement. Configuration of the major enantiomer is unreported

Bolm and co-workers subsequently reported an iron(III) PyBOX catalyst system for highly enantioselective sulfimidation reactions.<sup>127</sup> A single example of enantioselective



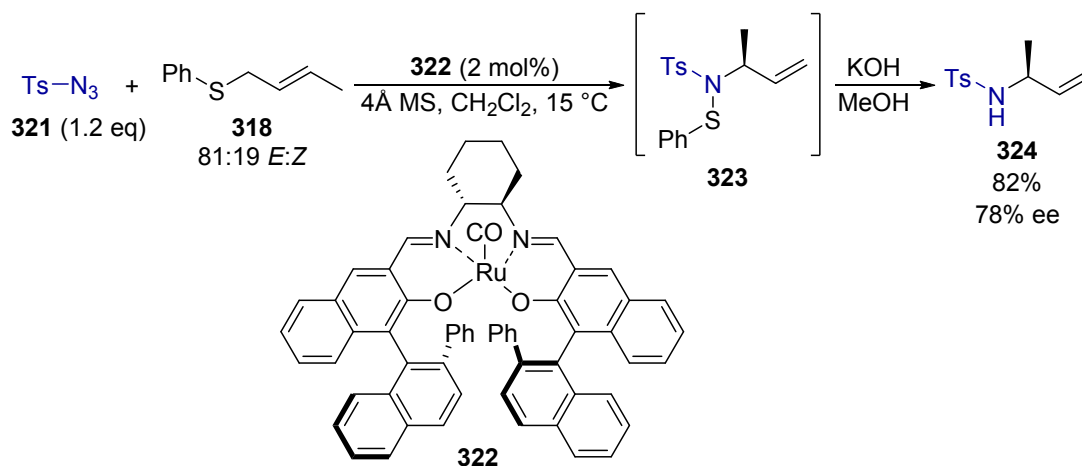

**Scheme 77.** Tandem sulfimidation and [2,3]-rearrangement using tosyl azide **321**

Tambar and co-workers have developed a two-step method for the conversion of unactivated terminal alkenes into sulfonamides through a sequential hetero-ene reaction and enantioselective palladium-catalyzed formal [2,3]-rearrangement protocol.<sup>129</sup> Reacting terminal alkenes **326** with benzenesulfonyl sulfurdiiimide **325** forms stable sulfimides **327** through a hetero-ene reaction. Sulfimides such as **327** could be purified by filtration and did not undergo un-catalyzed background [2,3]-rearrangement at low temperatures. Treating sulfimide **327** with  $\text{Pd}(\text{TFA})_2$  (10 mol%) and BOX ligand **316** (12 mol%) promoted a highly enantioselective [2,3]-rearrangement to form allylic sulfonamides **328** (Scheme 78a). This reaction sequence was applicable to substrates possessing an impressive range of aliphatic substituents at the homoallylic position, including those containing benzyl ether, phthalimide, nitrile, aldehyde, or alkyl chloride functional groups. In all cases the corresponding sulfonamide products were obtained in high yields with excellent enantioselectivity. Interestingly, this catalytic system was not suitable for substrates containing aryl substituents in the homoallylic position, giving sulfonamide products **331** with essentially no enantioselectivity.<sup>130</sup> However, using alternative BOX ligand **330** and 1,2-DCE as the reaction solvent a range of aryl substituents was tolerated, including those bearing both electron-withdrawing and electron-donating substituents, forming sulfonamides **331** in high

yields with excellent enantioselectivity (Scheme 78b). The synthetic utility of these methodologies was exemplified through the synthesis of the antiepileptic drug vigabatrin **332** and the enantiomer of peptidase inhibitor sitagliptin *ent*-**333**, approved for the treatment of Type II diabetes (Scheme 78c).<sup>129-130</sup> Mechanistically, the palladium-BOX complex is proposed to bind to  $\pi$ -system of intermediate sulfimide **327** to promote aminopalladation, with subsequent fragmentation of the five-membered cyclic intermediate giving the formal [2,3]-rearranged sulfonamide **328**.

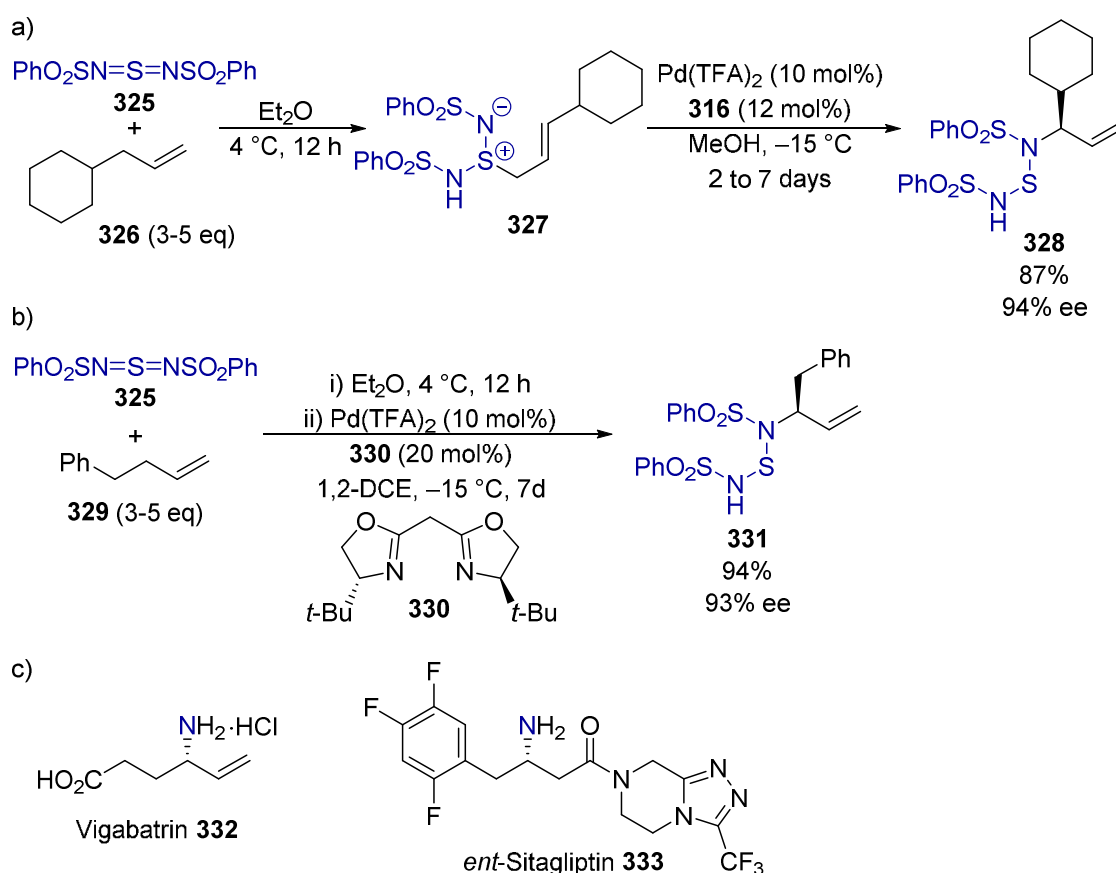

**Scheme 78.** Tandem homo-ene reaction and palladium-catalyzed [2,3]-rearrangement of terminal alkenes bearing a) aliphatic homoallylic substituents and b) aryl homoallylic substituents. c) Pharmaceutically active compounds synthesized using this methodology

### 5.3 Catalytic [2,3]-Rearrangement of Allylic *N*-Oxides

The [2,3]-rearrangement of allylic *N*-oxides into hydroxylamine derivatives was first reported by Meisenheimer in 1919 and the reaction often bears his name.<sup>131</sup> Although there has been

some limited success in developing stoichiometric stereoselective versions of the Meisenheimer rearrangement, a catalytic version remained elusive for many years.<sup>131</sup> In 2011, Tambar and co-workers reported the first such catalytic enantioselective [2,3]-rearrangement of amine *N*-oxides.<sup>132</sup> Allylic amines **334** were first oxidized into isolable allylic *N*-oxides **335** using *m*-CPBA. Treating allylic *N*-oxides **335** with Pd(OAc)<sub>2</sub> (10 mol%) and phosphoramidite ligand **336** (24 mol%) promoted the highly enantioselective [2,3]-rearrangement into allylic hydroxylamines **337** (Scheme 79). The addition of catalytic amounts of MeOH and *m*-CPBA gave a slight increase in the enantioselectivity, although the exact role of these additives is currently unknown. The reaction was applicable to a variety of aliphatic allylic *N*-oxides **335** including those bearing pendent alcohol, ether, aldehyde, and phosphate ester functional groups, forming hydroxylamines **337** in good yields and excellent enantioselectivity. The palladium(II) phosphoramidite catalyst is proposed to activate the allylic *N*-oxide to enantioselective oxypalladation, with fragmentation of the resulting heterocyclic intermediate giving the formal [2,3]-rearranged products. This presence of a heterocyclic intermediate is supported by the fact that *C*2 substituted substrates do not undergo rearrangement, while crossover experiments suggest that an allylpalladium intermediate is unlikely.

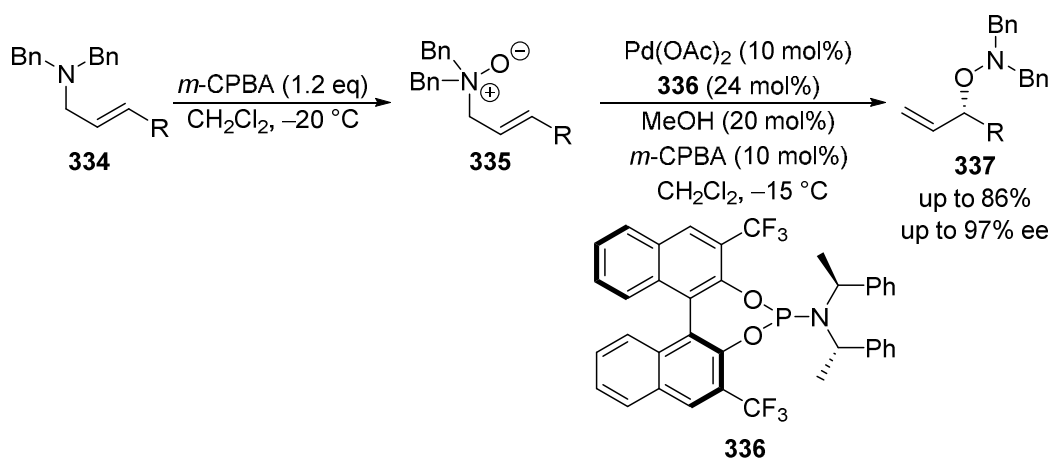

**Scheme 79.** Palladium catalyzed [2,3]-rearrangement of allylic *N*-oxides to form hydroxylamines **337**



## 6. CATALYTIC [2,3]-WITTIG REARRANGEMENTS

The base-promoted anionic [2,3]-Wittig rearrangement of allylic ethers into homoallylic alcohols has been widely used in organic synthesis.<sup>1a</sup> These reactions can be highly stereoselective depending upon the nature of any substituents, with the transition-state models calculated by Houk and Marshall often used to rationalize any diastereoselectivity observed.<sup>4</sup> However, catalytic asymmetric [2,3]-Wittig rearrangements remain an underdeveloped area, probably due to the typical requirement for a strong base to promote anionic [2,3]-rearrangements.

### 6.1 Base-Catalyzed [2,3]-Wittig Rearrangements

One strategy for rendering base-mediated [2,3]-Wittig rearrangements asymmetric is the use of stoichiometric amounts of chiral ligands. Kimachi and co-workers first reported the use of a catalytic amount of chiral ligand for the [2,3]-rearrangement of allylic ether **338** (Scheme 80a).<sup>133</sup> Treating **338** with an excess of *n*-BuLi and catalytic (–)-sparteine **339** (20 mol%) at low temperature gave homoallylic alcohol **340** in 44% yield and 48% ee, compared with 83% yield and 60% ee when an excess of (–)-sparteine **339** (2.2 eq) was used. Building upon earlier reports of chiral BOX ligands in [2,3]-rearrangements,<sup>134</sup> Maezaki and co-workers reported catalytic [2,3]-Wittig rearrangement of allylic ether using ligand **121** (50 mol%) and a large excess of *t*-BuLi to form homoallylic alcohol **342** in 52% yield as a single diastereoisomer in excellent 98% ee (Scheme 80b). Lower amounts of ligand (10 mol%) could be used, but although the high stereoselectivity was retained a decrease in yield (23%, >95:5 dr, 98% ee) was observed.<sup>135</sup>

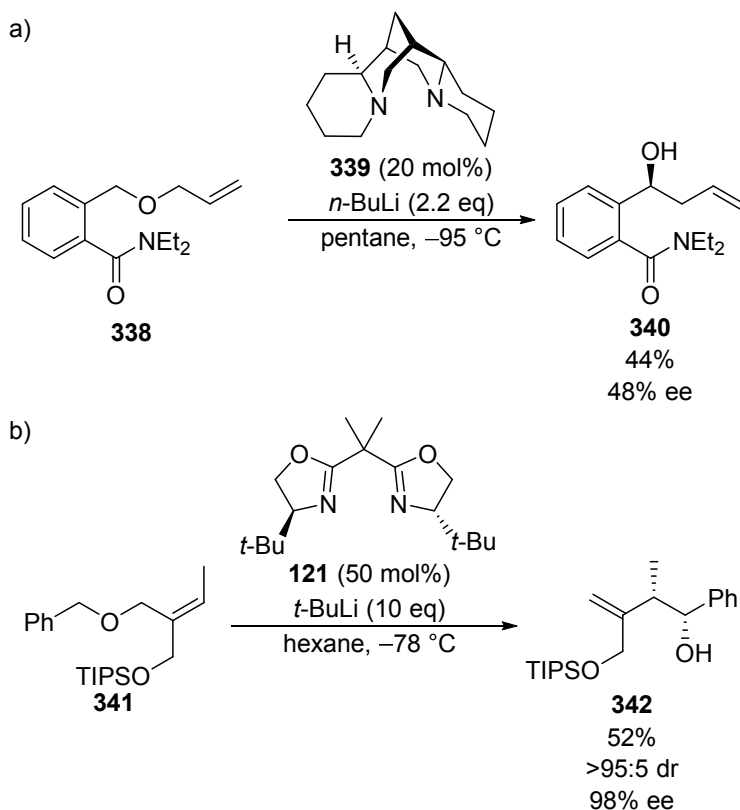

**Scheme 80.** Asymmetric base-mediated [2,3]-Wittig rearrangements using catalytic chiral ligands

Terada and Kondoh reported the first [2,3]-Wittig rearrangement that was catalytic in Brønsted base by utilizing a tandem phospho-Brook rearrangement.<sup>136</sup> Treating allyloxyphosphonate **343** with catalytic  $\text{KO}t\text{-Bu}$  (10 mol%) resulted in deprotonation followed by [2,3]-rearrangement into alkoxide **344** (Scheme 81). Subsequent phospho-Brook rearrangement of **344** followed by protonation to regenerate the catalyst gave product **345** in 85% yield and 68:32 dr. The reaction was applicable to a range of substituted allyloxyphosphonates forming the products in generally high yield but modest diastereoselectivity. Cyclic allyloxyphosphonates underwent the tandem reaction sequence to form ring-contracted lactone products with slightly higher levels of diastereoselectivity.

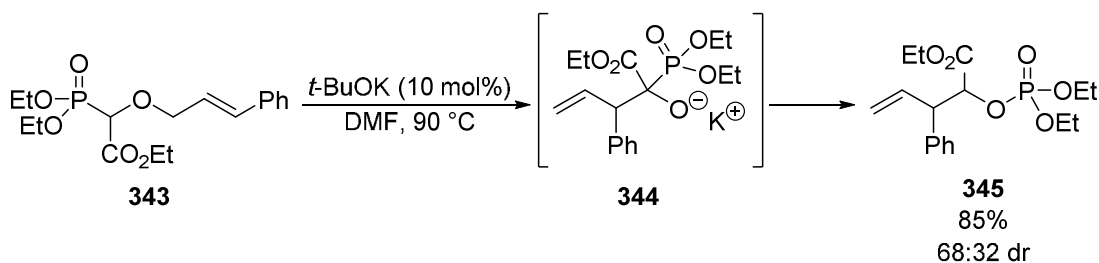

**Scheme 81.** Catalytic tandem [2,3]-Wittig rearrangement and phospho-Brook rearrangement. Configuration of the major diastereoisomer is unreported

Gaunt and co-workers reported a conceptually new method of performing stereoselective [2,3]-Wittig rearrangements using organocatalysts under mild conditions without the use of a strong base.<sup>137</sup> Using pyrrolidine **347** as a catalyst,  $\alpha$ -allyloxy ketone **346** reacts to form an enamine that can undergo highly diastereoselective [2,3]-rearrangement into homoallylic alcohol **348** in good yield (Scheme 82a). The *syn*-diastereoselectivity could be further improved to 91:9 dr by lowering the reaction temperature to  $-25^\circ\text{C}$ , although a significantly longer reaction time was needed to achieve complete conversion. The use of methanol as solvent was essential for obtaining diastereoselectivity, suggesting that the protic solvent is involved in hydrogen-bonding to the substrate during the rearrangement. The reaction of an enantiomerically enriched allylic ether resulted in complete chirality transfer into the product, suggesting a concerted mechanism is in operation. The reaction was applicable to a range of aliphatic ketones as well as allylic ethers bearing alkyl, aryl, alkynyl, and alkenyl functional groups, forming the homoallylic alcohol products in high yields with mostly good diastereoselectivity. In a single example, chiral proline derivative **350** was investigated as an enantioselective catalyst for this process, promoting the rearrangement of  $\alpha$ -allyloxy ketone **349** into alcohol **351** in 75% yield with moderate diastereoselectivity but promising 60% ee (Scheme 82b).

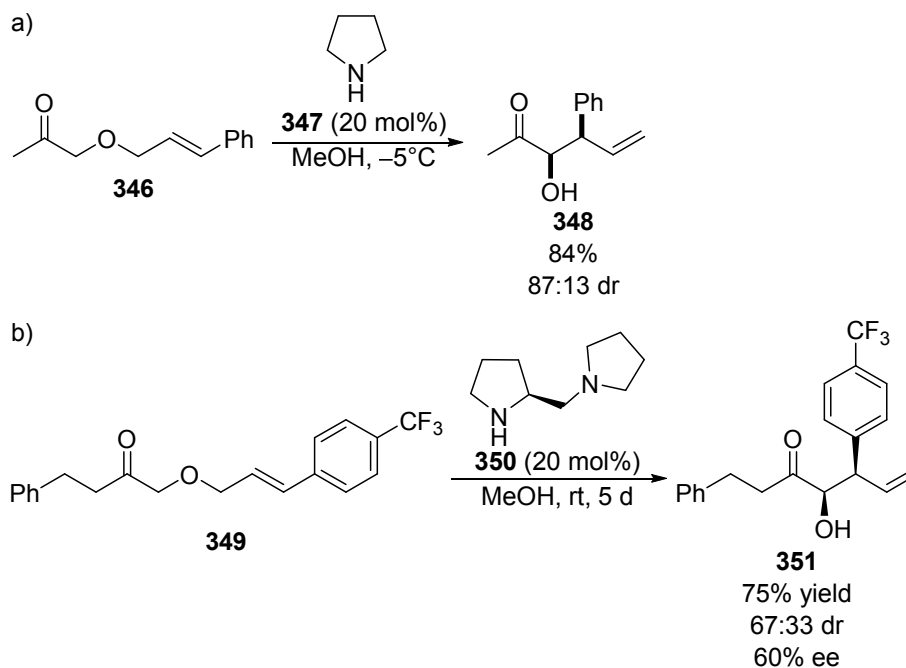

Scheme 82. Stereoselective organocatalytic [2,3]-Wittig rearrangements

## 6.2 Non-Base-Catalyzed [2,3]-Wittig Rearrangements

30  
31  
32  
33  
34  
35  
36  
37  
38  
39  
40  
41  
42  
43  
44  
45  
46  
47  
48  
49

While [2,3]-Wittig rearrangements are traditionally performed using strong inorganic bases, a few examples of non-base catalyzed [2,3]-rearrangements of allyloxy ethers have been reported. In 1986, Nakai and co-workers found that silyl ketene acetals such as **352** undergo highly diastereoselective [2,3]-rearrangements in the presence of catalytic trimethylsilyl triflate (20 mol%) at low temperature.<sup>138</sup> It is proposed that trimethylsilyl triflate reacts with the ether oxygen of **352** to form a silyloxonium salt, with subsequent reaction of the triflate anion with the silyl ketene acetal forming silyloxonium ylide **353** and regenerating the catalyst. Ylide **353** can then undergo a diastereoselective [2,3]-rearrangement *via* an *endo*-transition state to form  $\alpha$ -hydroxy ester **354** in high yield and >95:5 dr (Scheme 83).

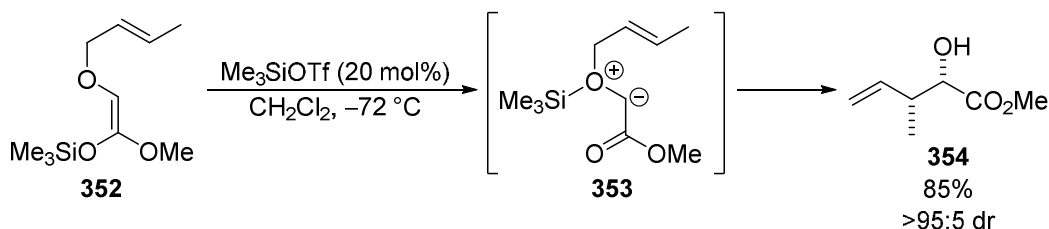

**Scheme 83.** Diastereoselective [2,3]-Wittig rearrangement catalyzed by trimethylsilyl triflate

More recently, Porco and co-workers synthesized a range of enantiomerically enriched 3,4-chromanedione derivatives through the scandium-catalyzed rearrangement of 3-allyloxyflavones.<sup>139</sup> For example, treating **355** with Sc(OTf)<sub>3</sub> (30 mol%) and PyBOX ligand **319** (30 mol%) gave rearranged 3,4-chromanedione **357**, which was immediately reacted with 1,2-ethylenediamine to allow dihydropyrazine **358** to be isolated in 98% yield and 94% ee (Scheme 84). Various 2-aryl and benzenoid substituents were tolerated and a few different diamines were utilized to form substituted dihydropyrazines in excellent yield and enantioselectivity. Preliminary mechanistic studies using both fluorescence and <sup>13</sup>C NMR spectroscopy favor an enantioselective scandium-catalyzed [2,3]-rearrangement into benzopyrylium **356** followed by a stereospecific [1,2]-allyl shift into **357** over a direct [3,3]-sigmatropic rearrangement of the allyl vinyl ether.

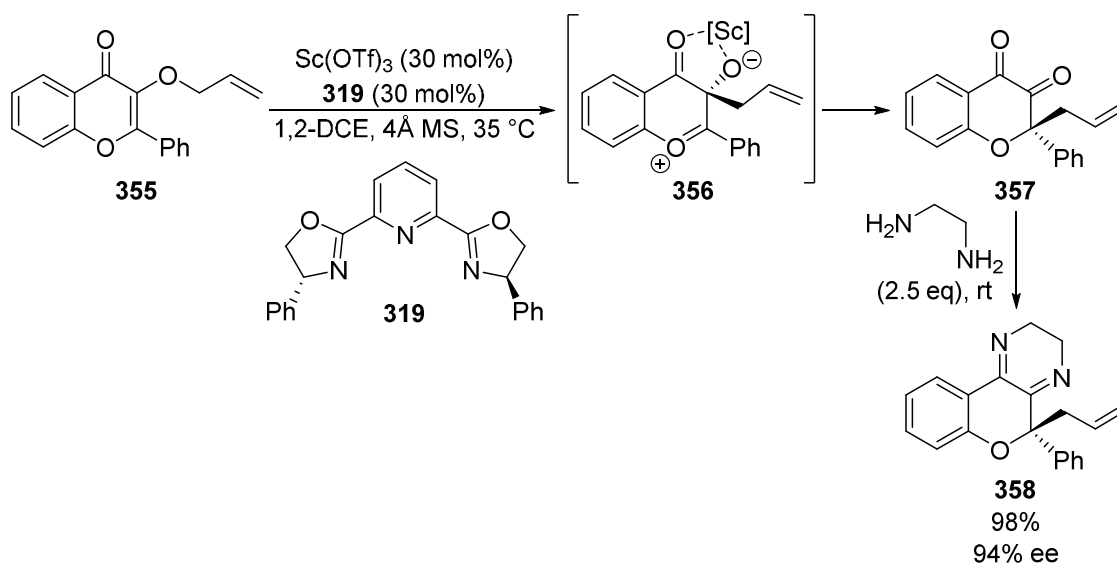
**Scheme 84.** Enantioselective synthesis of 3,4-chromanedione derivatives

More complex cascade processes utilizing [2,3]-Wittig rearrangements for the synthesis of nitrogen heterocycles using metallonitrene intermediates have been investigated by Blakey and co-workers.<sup>140</sup> For example, sulfamate ester **359** and enantiomerically pure allylic ether

**360** react under oxidative rhodium catalysis to selectively give **361** in 64% yield as a 73:27 *E:Z* mixture in 80% ee (Scheme 85a).<sup>140b</sup> Product **361** was subsequently derivatized into the core AB-ring system of the *Securinega* alkaloid family of natural products. The cascade reaction was applicable to a range of terminal allylic ethers, but only modest diastereoselectivity was obtained with substituted allylic ethers. The proposed mechanism involves a metallonitrene-initiated alkyne oxidation, with nucleophilic attack of benzyl ether **360** onto intermediate **363** leading oxonium **364** (Scheme 85b). Stereospecific [2,3]-rearrangement of **364** forms product **361** and releases the catalyst.

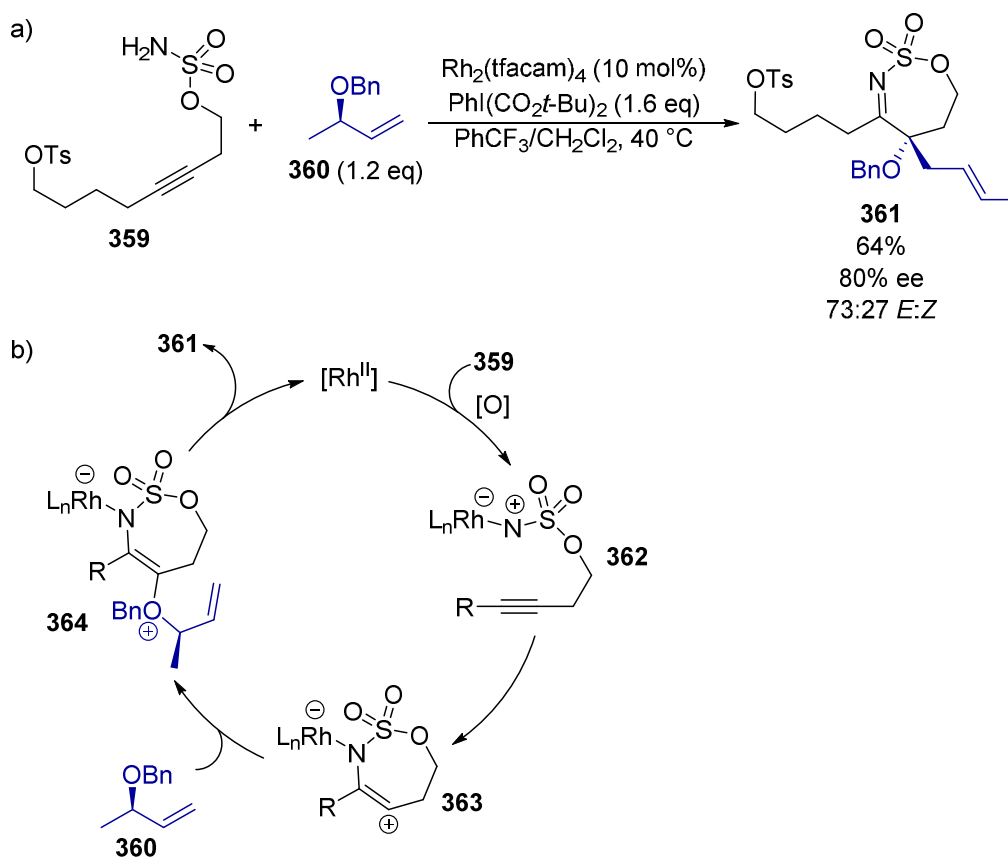

**Scheme 85.** Rhodium-catalyzed cascade process to form nitrogen heterocycles. tfacam = trifluoroacetamide

## 7. CONCLUSION AND OUTLOOK

Catalytic stereoselective [2,3]-rearrangements are powerful methods in asymmetric synthesis.

Many efficient catalytic protocols have been developed for a diverse range of [2,3]-

1  
2  
3 rearrangements, allowing new carbon-carbon and/or carbon-heteroatom bonds to be formed  
4  
5 with high levels of diastereo- and enantioselectivity. The synthetic utility of a number of  
6  
7 these methodologies have also been demonstrated through the synthesis of target molecules.  
8  
9

10 The [2,3]-rearrangement of onium ylides generated catalytically through reaction of a metal  
11  
12 carbenoid remains the most widely explored methodology in the area. However, there is an  
13  
14 increasing number of alternative catalytic strategies available using different methods of  
15  
16 accessing reactive intermediates capable of undergoing stereoselective [2,3]-rearrangements.  
17  
18 The incorporation of stereoselective [2,3]-rearrangements within tandem catalytic processes  
19  
20 is an expanding area of research that is likely to increase further in the future.  
21  
22  
23

24 Although the number of catalytic asymmetric [2,3]-rearrangements has increased  
25  
26 dramatically over the last 20 years, there is still room for improvement in many areas. While  
27  
28 highly diastereoselective reactions are more readily attained, the development of highly  
29  
30 enantioselective variants remains a significant challenge in many cases. The ability to  
31  
32 rationally design effective enantioselective protocols is often hampered by the limited  
33  
34 detailed mechanistic understanding of many of these processes. Therefore an increased  
35  
36 understanding of how catalysts interact and participate in [2,3]-rearrangements is likely to be  
37  
38 hugely beneficial for the further development of highly stereoselective reactions.  
39  
40  
41  
42

43 Given the demonstrated synthetic utility of [2,3]-rearrangements, the further development of  
44  
45 highly stereoselective catalytic variants will remain an active and worthwhile area of  
46  
47 research. The design of new substrates capable of undergoing [2,3]-rearrangement processes  
48  
49 as well as incorporation of known [2,3]-rearrangements within complex cascade reactions are  
50  
51 also likely to lead to further advances in this field.  
52  
53  
54  
55  
56  
57  
58  
59  
60

## AUTHOR INFORMATION

### Corresponding Author

E-mail: ads10@st-andrews.ac.uk

### Notes

The authors declare no competing financial interest.

## ACKNOWLEDGEMENTS

We thank the Royal Society for a University Research Fellowship (A.D.S.), the European Research Council under the European Union's Seventh Framework Programme (FP7/2007-2013) ERC Grant Agreement No. 279850 (J.E.T., T.H.W., K.K.), and the European Union (Marie Curie ITN 'SuBiCat' PITN-GA-2013-607044) (S.S.M.S.) for financial support.

## REFERENCES

- (1) (a) Nakai, T.; Mikami, K. *Chem. Rev.* **1986**, *86*, 885-902. (b) Mikami, K.; Nakai, T. *Synthesis* **1991**, *1991*, 594-604. (c) *Nitrogen, Oxygen, and Sulfur Ylide Chemistry: A Practical Approach in Chemistry*; Clark, J. S. Ed.; Oxford University Press: New York, 2002; p 1-308. (d) Sweeney, J. B. *Chem. Soc. Rev.* **2009**, *38*, 1027-1038. (e) Murphy, G. K.; Stewart, C.; West, F. G. *Tetrahedron* **2013**, *69*, 2667-2686.
- (2) Jones, A. C.; May, J. A.; Sarpong, R.; Stoltz, B. M. *Angew. Chem. Int. Ed.* **2014**, *53*, 2556-2591.
- (3) Hoffmann, R. W. *Angew. Chem. Int. Ed.* **1979**, *18*, 563-572.
- (4) Wu, Y. D.; Houk, K. N.; Marshall, J. A. *J. Org. Chem.* **1990**, *55*, 1421-1423.
- (5) Hoffmann, R. W. *Chem. Rev.* **1989**, *89*, 1841-1860.
- (6) (a) Doyle, M. P. *Chem. Rev.* **1986**, *86*, 919-939. (b) Doyle, M. P.; Forbes, D. C. *Chem. Rev.* **1998**, *98*, 911-936. (c) Doyle, M. P. *Russ Chem Bull* **1999**, *48*, 16-20.



- 1  
2  
3 (7) Doyle, M. P.; Bagheri, V.; Harn, N. K. *Tetrahedron Lett.* **1988**, *29*, 5119-5122.  
4  
5 (8) Doyle, M. P.; Forbes, D. C.; Vasbinder, M. M.; Peterson, C. S. *J. Am. Chem. Soc.* **1998**,  
6  
7 *120*, 7653-7654.  
8  
9 (9) Quinn, K. J.; Biddick, N. A.; DeChristopher, B. A. *Tetrahedron Lett.* **2006**, *47*, 7281-  
10  
11 7283.  
12  
13 (10) Mack, D. J.; Batory, L. A.; Njardarson, J. T. *Org. Lett.* **2011**, *14*, 378-381.  
14  
15 (11) Li, Z.; Davies, H. M. L. *J. Am. Chem. Soc.* **2009**, *132*, 396-401.  
16  
17 (12) Li, Z.; Parr, B. T.; Davies, H. M. L. *J. Am. Chem. Soc.* **2012**, *134*, 10942-10946.  
18  
19 (13) Li, Z.; Boyarskikh, V.; Hansen, J. H.; Autschbach, J.; Musaev, D. G.; Davies, H. M. L.  
20  
21 *J. Am. Chem. Soc.* **2012**, *134*, 15497-15504.  
22  
23 (14) Chepiga, K. M.; Feng, Y.; Brunelli, N. A.; Jones, C. W.; Davies, H. M. L. *Org. Lett.*  
24  
25 **2013**, *15*, 6136-6139.  
26  
27 (15) (a) Parr, B. T.; Li, Z.; Davies, H. M. L. *Chem. Sci.* **2011**, *2*, 2378-2382. (b) Parr, B. T.;  
28  
29 Davies, H. M. L. *Nat. Commun.* **2014**, *5*, 4455  
30  
31 (16) Parr, B. T.; Davies, H. M. L. *Org. Lett.* **2015**, *17*, 794-797.  
32  
33 (17) Roskamp, E. J.; Johnson, C. R. *J. Am. Chem. Soc.* **1986**, *108*, 6062-6063.  
34  
35 (18) Pirrung, M. C.; Werner, J. A. *J. Am. Chem. Soc.* **1986**, *108*, 6060-6062.  
36  
37 (19) Pirrung, M. C.; Brown, W. L.; Rege, S.; Laughton, P. *J. Am. Chem. Soc.* **1991**, *113*,  
38  
39 8561-8562.  
40  
41 (20) Clark, J. S. *Tetrahedron Lett.* **1992**, *33*, 6193-6196.  
42  
43 (21) Clark, J. S.; Romiti, F. *Angew. Chem. Int. Ed.* **2013**, *52*, 10072-10075.  
44  
45 (22) (a) Clark, J. S.; Labre, F.; Thomas, L. H. *Org. Biomol. Chem.* **2011**, *9*, 4823-4830. (b)  
46  
47 Clark, J. S.; Yang, G.; Osnowski, A. P. *Org. Lett.* **2013**, *15*, 1460-1463. (c) Clark, J. S.;  
48  
49 Yang, G.; Osnowski, A. P. *Org. Lett.* **2013**, *15*, 1464-1467.  
50  
51 (23) Clark, J. S.; Fessard, T. C.; Wilson, C. *Org. Lett.* **2004**, *6*, 1773-1776.  
52  
53  
54  
55  
56  
57  
58  
59  
60

- 1  
2  
3 (24) Yakura, T.; Ozono, A.; Matsui, K.; Yamashita, M.; Fujiwara, T. *Synlett* **2013**, *24*, 65-68.  
4  
5 (25) Clark, J. S.; Hansen, K. E. *Chem. Eur. J.* **2014**, *20*, 5454-5459.  
6  
7 (26) Hodgson, D. M.; Angrish, D.; Erickson, S. P.; Kloesges, J.; Lee, C. H. *Org. Lett.* **2008**,  
8  
9 *10*, 5553-5556.  
10  
11 (27) Hodgson, D. M.; Man, S. *Chem. Eur. J.* **2011**, *17*, 9731-9737.  
12  
13 (28) Hodgson, D. M.; Man, S.; Powell, K. J.; Perko, Z.; Zeng, M.; Moreno-Clavijo, E.;  
14  
15 Thompson, A. L.; Moore, M. D. *J. Org. Chem.* **2014**, *79*, 9728-9734.  
16  
17 (29) Clark, J. S.; Whitlock, G. A. *Tetrahedron Lett.* **1994**, *35*, 6381-6382.  
18  
19 (30) Clark, J. S.; Fessard, T. C.; Whitlock, G. A. *Tetrahedron* **2006**, *62*, 73-78.  
20  
21 (31) Clark, J. S.; Hayes, S. T.; Wilson, C.; Gobbi, L. *Angew. Chem. Int. Ed.* **2007**, *46*, 437-  
22  
23 440.  
24  
25 (32) (a) Clark, J. S.; Berger, R.; Hayes, S. T.; Thomas, L. H.; Morrison, A. J.; Gobbi, L.  
26  
27 *Angew. Chem. Int. Ed.* **2010**, *49*, 9867-9870. (b) Clark, J. S.; Wong, Y.-S. *Chem. Commun.*  
28  
29 **2000**, 1079-1080.  
30  
31 (33) Clark, J. S.; Delion, L.; Farrugia, L. J. *Org. Lett.* **2014**, *16*, 4300-4303.  
32  
33 (34) Clark, J. S.; Vignard, D.; Parkin, A. *Org. Lett.* **2011**, *13*, 3980-3983.  
34  
35 (35) Marmsäter, F. P.; West, F. G. *J. Am. Chem. Soc.* **2001**, *123*, 5144-5145.  
36  
37 (36) Jaber, D. M.; Burgin, R. N.; Helper, M.; Zavalij, P. Y.; Doyle, M. P. *Org. Lett.* **2012**, *14*,  
38  
39 1676-1679.  
40  
41 (37) Han, M.; Bae, J.; Choi, J.; Tae, J. *Synlett* **2013**, *24*, 2077-2080.  
42  
43 (38) Fu, J.; Shang, H.; Wang, Z.; Chang, L.; Shao, W.; Yang, Z.; Tang, Y. *Angew. Chem. Int.*  
44  
45 *Ed.* **2013**, *52*, 4198-4202.  
46  
47 (39) Boyer, A. *Org. Lett.* **2014**, *16*, 1660-1663.  
48  
49 (40) Boyer, A. *J. Org. Chem.* **2015**, *80*, 4771-4775.  
50  
51 (41) Boyer, A. *Org. Lett.* **2014**, *16*, 5878-5881.  
52  
53  
54  
55  
56  
57  
58  
59  
60

- 1  
2  
3 (42) McCarthy, N.; McKerverey, M. A.; Ye, T.; McCann, M.; Murphy, E.; Doyle, M. P.  
4  
5 *Tetrahedron Lett.* **1992**, *33*, 5983-5986.  
6  
7 (43) Hodgson, D. M.; Petroliagi, M. *Tetrahedron: Asymmetry* **2001**, *12*, 877-881.  
8  
9 (44) Ferris, L.; Haigh, D.; Moody, C. J. *Tetrahedron Lett.* **1996**, *37*, 107-110.  
10  
11 (45) Pierson, N.; Fernández-García, C.; McKerverey, M. A. *Tetrahedron Lett.* **1997**, *38*, 4705-  
12  
13 4708.  
14  
15 (46) Kitagaki, S.; Yanamoto, Y.; Tsutsui, H.; Anada, M.; Nakajima, M.; Hashimoto, S.  
16  
17 *Tetrahedron Lett.* **2001**, *42*, 6361-6364.  
18  
19 (47) Calter, M. A.; Sugathapala, P. M. *Tetrahedron Lett.* **1998**, *39*, 8813-8816.  
20  
21 (48) Shimada, N.; Nakamura, S.; Anada, M.; Shiro, M.; Hashimoto, S. *Chem. Lett.* **2009**, *38*,  
22  
23 488-489.  
24  
25 (49) Clark, J. S.; Fretwell, M.; Whitlock, G. A.; Burns, C. J.; Fox, D. N. A. *Tetrahedron Lett.*  
26  
27 **1998**, *39*, 97-100.  
28  
29 (50) Doyle, M. P.; Peterson, C. S. *Tetrahedron Lett.* **1997**, *38*, 5265-5268.  
30  
31 (51) Doyle, M. P.; Tamblyn, W. H.; Bagheri, V. *J. Org. Chem.* **1981**, *46*, 5094-5102.  
32  
33 (52) Zhou, C.-Y.; Yu, W.-Y.; Chan, P. W. H.; Che, C.-M. *J. Org. Chem.* **2004**, *69*, 7072-  
34  
35 7082.  
36  
37 (53) Heath, P.; Roberts, E.; Sweeney, J. B.; Wessel, H. P.; Workman, J. A. *J. Org. Chem.*  
38  
39 **2003**, *68*, 4083-4086.  
40  
41 (54) (a) Roberts, E.; Sançon, J. P.; Sweeney, J. B.; Workman, J. A. *Org. Lett.* **2003**, *5*, 4775-  
42  
43 4777. (b) Sançon, J.; Sweeney, J. B. *Synlett* **2010**, 664-666.  
44  
45 (55) Sançon, J.; Sweeney, J. B. *Synlett* **2008**, 2213-2214.  
46  
47 (56) Clark, J. S.; Hodgson, P. B. *J. Chem. Soc., Chem. Commun.* **1994**, 2701-2702.  
48  
49 (57) Clark, J. S.; Hodgson, P. B.; Goldsmith, M. D.; Blake, A. J.; Cooke, P. A.; Street, L. J. *J.*  
50  
51 *Chem. Soc., Perkin Trans. 1* **2001**, 3325-3337.  
52  
53  
54  
55  
56  
57  
58  
59  
60

- 1  
2  
3 (58) Clark, J. S.; Hodgson, P. B.; Goldsmith, M. D.; Street, L. J. *J. Chem. Soc., Perkin Trans.*  
4  
5 *1* **2001**, 3312-3324.  
6  
7 (59) Clark, J. S.; Hodgson, P. B. *Tetrahedron Lett.* **1995**, *36*, 2519-2522.  
8  
9 (60) Wright, D. L.; Weekly, R. M.; Groff, R.; McMills, M. C. *Tetrahedron Lett.* **1996**, *37*,  
10 2165-2168.  
11  
12 (61) Rowlands, G. J.; Kentish Barnes, W. *Tetrahedron Lett.* **2004**, *45*, 5347-5350.  
13  
14 (62) Trost, B. M.; Hammen, R. F. *J. Am. Chem. Soc.* **1973**, *95*, 962-964.  
15  
16 (63) Grieco, P. A.; Boxler, D.; Hiroi, K. *J. Org. Chem.* **1973**, *38*, 2572-2573.  
17  
18 (64) Yoshimoto, M.; Ishihara, S.; Nakayama, E.; Soma, N. *Tetrahedron Lett.* **1972**, *13*, 2923-  
19 2926.  
20  
21 (65) (a) Giddings, P. J.; D. Ivor, J.; Thomas, E. J. *Tetrahedron Lett.* **1980**, *21*, 395-398. (b)  
22 Giddings, P. J.; D. Ivor, J.; Thomas, E. J.; Williams, D. J. *J. Chem. Soc., Perkin Trans. 1*  
23 **1982**, *14*, 2757-2766.  
24  
25 (66) Vedejs, E.; Hagen, J. P.; Roach, B. L.; Spear, K. L. *J. Org. Chem.* **1978**, *43*, 1185-1190.  
26  
27 (67) Doyle, M. P.; Griffin, J. H.; Chinn, M. S.; Van Leusen, D. *J. Org. Chem.* **1984**, *49*,  
28 1917-1925.  
29  
30 (68) Stepanov, A. V.; Molchanov, A. P.; Magull, J.; Vidović, D.; Starova, G. L.; Kopf, J.;  
31 Kostikov, R. R. *Tetrahedron* **2006**, *62*, 3610-3618.  
32  
33 (69) (a) Gulea, M.; Marchand, P.; Masson, S.; Saquet, M.; Collignon, N. *Synthesis* **1998**, *11*,  
34 1635-1639. (b) Gulea, M.; Marchand, P.; Saquet, M.; Masson, S.; Collignon, N. *Phosphorus,*  
35 *Sulfur, and Silicon and the Related Elements* **1999**, *153*, 327-328.  
36  
37 (70) Vedejs, E.; Hagen, J. P. *J. Am. Chem. Soc.* **1975**, *97*, 6878-6880.  
38  
39 (71) Nickon, A.; Rodriguez, A. D.; Ganguly, R.; Shirhatti, V. *J. Org. Chem.* **1985**, *50*, 2767-  
40 2777.  
41  
42 (72) Shi, G.; Xu, Y.; Xu, M. *Tetrahedron* **1991**, *47*, 1629-1648.  
43  
44  
45  
46  
47  
48  
49  
50  
51  
52  
53  
54  
55  
56  
57  
58  
59  
60

- 1  
2  
3 (73) Müller, P.; Grass, S.; Shahi, S. P.; Bernardinelli, G. *Tetrahedron* **2004**, *60*, 4755-4763.  
4  
5 (74) Davies, P. W.; Albrecht, S. J. C.; Assanelli, G. *Org. Biomol. Chem.* **2009**, *7*, 1276-1279.  
6  
7 (75) (a) Aggarwal, V. K.; Ferrara, M.; Hainz, R.; Spey, S. E. *Tetrahedron Lett.* **1999**, *40*,  
8 8923-8927. (b) Carter, D. S.; Van Vranken, D. L. *Tetrahedron Lett.* **1999**, *40*, 1617-1620. (c)  
9 Carter, D. S.; Van Vranken, D. L. *Org. Lett.* **2000**, *2*, 1303-1305. (d) Perales, J. B.; Makino,  
10 N. F.; Van Vranken, D. L. *J. Org. Chem.* **2002**, *67*, 6711-6717.  
11  
12 (76) Greenman, K. L.; Carter, D. S.; Van Vranken, D. L. *Tetrahedron* **2001**, *57*, 5219-5225.  
13  
14 (77) Miura, T.; Tanaka, T.; Yada, A.; Murakami, M. *Chem. Lett.* **2013**, *42*, 1308-1310.  
15  
16 (78) Zhang, H.; Wang, B.; Yi, H.; Zhang, Y.; Wang, J. *Org. Lett.* **2015**, *17*, 3322-3325.  
17  
18 (79) Kato, Y.; Miki, K.; Nishino, F.; Ohe, K.; Uemura, S. *Org. Lett.* **2003**, *5*, 2619-2621.  
19  
20 (80) (a) Davies, P. W.; Albrecht, S. J. C. *Chem. Commun.* **2008**, 238-240. (b) Davies, P. W.;  
21 Albrecht, S. J. C. *Synlett* **2012**, 70-73.  
22  
23 (81) Davies, P. W.; Albrecht, S. J. C. *Angew. Chem. Int. Ed.* **2009**, *48*, 8372-8375.  
24  
25 (82) Li, J.; Ji, K.; Zheng, R.; Nelson, J.; Zhang, L. *Chem. Commun.* **2014**, *50*, 4130-4133.  
26  
27 (83) Dos Santos, M.; Davies, P. W. *Chem. Commun.* **2014**, *50*, 6001-6004.  
28  
29 (84) Nishibayashi, Y.; Ohe, K.; Uemura, S. *J. Chem. Soc., Chem. Commun.* **1995**, *31*, 1245-  
30 1246.  
31  
32 (85) McMillen, D. W.; Varga, N.; Reed, B. A.; King, C. *J. Org. Chem.* **2000**, *65*, 2532-2536.  
33  
34 (86) Zhang, X.; Qu, Z.; Ma, Z.; Shi, W.; Jin, X.; Wang, J. *J. Org. Chem.* **2002**, *67*, 5621-  
35 5625.  
36  
37 (87) Zhang, X.; Ma, M.; Wang, J. *Tetrahedron: Asymmetry* **2003**, *14*, 891-895.  
38  
39 (88) Zhang, X.-M.; Ma, M.; Wang, J.-B. *Chin. J. Chem.* **2003**, *21*, 878-882.  
40  
41 (89) Liao, M.; Wang, J. *Green Chem.* **2007**, *9*, 184-188.  
42  
43 (90) Kitagaki, S.; Yanamoto, Y.; Okubo, H.; Nakajima, M.; Hashimoto, S. *Heterocycles*  
44 **2001**, *54*, 623 - 628.  
45  
46  
47  
48  
49  
50  
51  
52  
53  
54  
55  
56  
57  
58  
59  
60

- 1  
2  
3 (91) (a) Fukuda, T.; Katsuki, T. *Tetrahedron Lett.* **1997**, *38*, 3435-3438. (b) Itoh, K.; Fukuda,  
4 T.; Kitajima, H.; Katsuki, T. *J. Synth. Org. Chem., Jpn.* **1997**, *55*, 764-773. (c) Fukuda, T.;  
5 Irie, R.; Katsuki, T. *Tetrahedron* **1999**, *55*, 649-664.  
6  
7  
8  
9  
10 (92) Ma, M.; Peng, L.; Li, C.; Zhang, X.; Wang, J. *J. Am. Chem. Soc.* **2005**, *127*, 15016-  
11 15017.  
12  
13  
14 (93) Wee, A. G. H.; Shi, Q.; Wang, Z.; Hatton, K. *Tetrahedron: Asymmetry* **2003**, *14*, 897-  
15 909.  
16  
17  
18 (94) (a) Kido, F.; Sinha, S. C.; Abiko, T.; Yoshikoshi, A. *Tetrahedron Lett.* **1989**, *30*, 1575-  
19 1578. (b) Kido, F.; Sinha, S. C.; Abiko, T.; Watanabe, M.; Yoshikoshi, A. *Tetrahedron* **1990**,  
20 *46*, 4887-4906.  
21  
22  
23 (95) Kido, F.; Sinha, S. C.; Abiko, T.; Watanabe, M.; Yoshikoshi, A. *J. Chem. Soc., Chem.*  
24 *Commun.* **1990**, 418-420.  
25  
26  
27 (96) Kurth, M. J.; Tahir, S. H.; Olmstead, M. M. *J. Org. Chem.* **1990**, *55*, 2286-2288.  
28  
29  
30 (97) Kido, F.; Kawada, Y.; Kato, M.; Yoshikoshi, A. *Tetrahedron Lett.* **1991**, *32*, 6159-6162.  
31  
32  
33 (98) Kido, F.; Kazi, A. B.; Yamaji, K.; Kato, M.; Yoshikoshi, A. *Heterocycles* **1992**, *33*, 607  
34 - 618.  
35  
36  
37 (99) (a) Kido, F.; Yamaji, K.; Sinha, S. C.; Yoshikoshi, A.; Kato, M. *J. Chem. Soc., Chem.*  
38 *Commun.* **1994**, 789-790. (b) Kido, F.; Yamaji, K.; Sinha, S. C.; Abiko, T.; Kato, M.  
39 *Tetrahedron* **1995**, *51*, 7697-7714.  
40  
41  
42 (100) Kido, F.; Abiko, T.; Kato, M. *J. Chem. Soc., Perkin Trans. 1* **1995**, 2989-2994.  
43  
44  
45 (101) Chappie, T. A.; Weekly, R. M.; McMills, M. C. *Tetrahedron Lett.* **1996**, *37*, 6523-  
46 6526.  
47  
48  
49 (102) (a) Kido, F.; Abiko, T.; Kazi, A. B.; Kato, M.; Yoshikoshi, A. *Heterocycles* **1991**, *32*,  
50 1487 - 1490. (b) Kido, F.; Abiko, T.; Kato, M. *J. Chem. Soc., Perkin Trans. 1* **1992**, 229-233.  
51  
52  
53  
54  
55  
56  
57  
58  
59  
60

- 1  
2  
3 (103) Krishnamoorthy, P.; Browning, R. G.; Singh, S.; Sivappa, R.; Lovely, C. J.; Dias, H. V.  
4  
5 R. *Chem. Commun.* **2007**, 731-733.  
6  
7 (104) Deng, Q.-H.; Chen, J.; Huang, J.-S.; Chui, S. S.-Y.; Zhu, N.; Li, G.-Y.; Che, C.-M.  
8  
9 *Chem. Eur. J.* **2009**, *15*, 10707-10712.  
10  
11 (105) Doyle, M. P.; Hu, W.; Phillips, I. M.; Moody, C. J.; Pepper, A. G.; Slawin, A. M. Z.  
12  
13 *Adv. Synth. Catal.* **2001**, *343*, 112-117.  
14  
15 (106) Soheili, A.; Tambar, U. K. *J. Am. Chem. Soc.* **2011**, *133*, 12956-12959.  
16  
17 (107) Soheili, A.; Tambar, U. K. *Org. Lett.* **2013**, *15*, 5138-5141.  
18  
19 (108) Nash, A.; Soheili, A.; Tambar, U. K. *Org. Lett.* **2013**, *15*, 4770-4773.  
20  
21 (109) West, T. H.; Daniels, D. S. B.; Slawin, A. M. Z.; Smith, A. D. *J. Am. Chem. Soc.* **2014**,  
22  
23 *136*, 4476-4479.  
24  
25 (110) (a) Nakamura, I.; Zhang, D.; Terada, M. *J. Am. Chem. Soc.* **2010**, *132*, 7884-7886. (b)  
26  
27 Nakamura, I.; Zhang, D.; Terada, M. *J. Am. Chem. Soc.* **2011**, *133*, 6862-6862.  
28  
29 (111) Nakamura, I.; Zhang, D.; Terada, M. *Tetrahedron Lett.* **2011**, *52*, 6470-6472.  
30  
31 (112) (a) Nakamura, I.; Araki, T.; Zhang, D.; Kudo, Y.; Kwon, E.; Terada, M. *Org. Lett.*  
32  
33 **2011**, *13*, 3616-3619. (b) Nakamura, I.; Kudo, Y.; Araki, T.; Zhang, D.; Kwon, E.; Terada,  
34  
35 M. *Synthesis* **2012**, 1542-1550.  
36  
37 (113) Nakamura, I.; Ishida, Y.; Terada, M. *Org. Lett.* **2014**, *16*, 2562-2565.  
38  
39 (114) Nakamura, I.; Okamoto, M.; Sato, Y.; Terada, M. *Angew. Chem. Int. Ed.* **2012**, *51*,  
40  
41 10816-10819.  
42  
43 (115) Nakamura, I.; Sato, Y.; Takeda, K.; Terada, M. *Chem. Eur. J.* **2014**, *20*, 10214-10219.  
44  
45 (116) Nakamura, I.; Kudo, Y.; Terada, M. *Angew. Chem. Int. Ed.* **2013**, *52*, 7536-7539.  
46  
47 (117) Zhou, Z. S.; Flohr, A.; Hilvert, D. *J. Org. Chem.* **1999**, *64*, 8334-8341.  
48  
49 (118) Hagiwara, H.; Isobe, K.; Numamae, A.; Hoshi, T.; Suzuki, T. *Synlett* **2006**, 1601-1603.  
50  
51  
52  
53  
54  
55  
56  
57  
58  
59  
60

- 1  
2  
3 (119) Miura, M.; Toriyama, M.; Kawakubo, T.; Yasukawa, K.; Takido, T.; Motohashi, S.  
4  
5 *Org. Lett.* **2010**, *12*, 3882-3885.  
6  
7 (120) Corey, E. J.; Wu, L. I. *J. Am. Chem. Soc.* **1993**, *115*, 9327-9328.  
8  
9 (121) Paquette, L. A.; Lobben, P. C. *J. Org. Chem.* **1998**, *63*, 5604-5616.  
10  
11 (122) Carter, R. G.; Bourland, T. C. *Chem. Commun.* **2000**, 2031-2032.  
12  
13 (123) Bourland, T. C.; Carter, R. G.; Yokochi, A. F. T. *Org. Biomol. Chem.* **2004**, *2*, 1315-  
14  
15 1329.  
16  
17 (124) Sharpless, K. B.; Hori, T. *J. Org. Chem.* **1976**, *41*, 176-177.  
18  
19 (125) (a) Takada, H.; Nishibayashi, Y.; Ohe, K.; Uemura, S. *Chem. Commun.* **1996**, 931-932.  
20  
21 (b) Takada, H.; Nishibayashi, Y.; Ohe, K.; Uemura, S.; Baird, C. P.; Sparey, T. J.; Taylor, P.  
22  
23 *C. J. Org. Chem.* **1997**, *62*, 6512-6518. (c) Takada, H.; Nishibayashi, Y.; Ohe, K.; Uemura, S.  
24  
25 *Phosphorus, Sulfur, and Silicon and the Related Elements* **1997**, *120*, 363-364.  
26  
27 (126) (a) Takada, H.; Miyake, Y.; Ohe, K.; Uemura, S. *Chem. Commun.* **1998**, 1557-1558.  
28  
29 (b) Miyake, Y.; Oda, M.; Oyamada, A.; Takada, H.; Ohe, K.; Uemura, S. *J. Organomet.*  
30  
31 *Chem.* **2000**, *611*, 475-487.  
32  
33 (127) Wang, J.; Frings, M.; Bolm, C. *Angew. Chem. Int. Ed.* **2013**, *52*, 8661-8665.  
34  
35 (128) (a) Murakami, M.; Katsuki, T. *Tetrahedron Lett.* **2002**, *43*, 3947-3949. (b) Murakami,  
36  
37 M.; Uchida, T.; Saito, B.; Katsuki, T. *Chirality* **2003**, *15*, 116-123.  
38  
39 (129) Bao, H.; Tambar, U. K. *J. Am. Chem. Soc.* **2012**, *134*, 18495-18498.  
40  
41 (130) Bao, H.; Bayeh, L.; Tambar, U. K. *Synlett* **2013**, *24*, 2459-2463.  
42  
43 (131) Bao, H.; Qi, X.; Tambar, U. K. *Synlett* **2011**, 1789-1792.  
44  
45 (132) Bao, H.; Qi, X.; Tambar, U. K. *J. Am. Chem. Soc.* **2011**, *133*, 1206-1208.  
46  
47 (133) Kawasaki, T.; Kimachi, T. *Tetrahedron* **1999**, *55*, 6847-6862.  
48  
49 (134) Tomooka, K.; Komine, N.; Nakai, T. *Chirality* **2000**, *12*, 505-509.  
50  
51 (135) Kitamura, M.; Hirokawa, Y.; Maezaki, N. *Chem. Eur. J.* **2009**, *15*, 9911-9917.  
52  
53  
54  
55  
56  
57  
58  
59  
60



- 1  
2  
3 (136) Kondoh, A.; Terada, M. *Org. Lett.* **2013**, *15*, 4568-4571.  
4  
5 (137) McNally, A.; Evans, B.; Gaunt, M. J. *Angew. Chem. Int. Ed* **2006**, *45*, 2116-2119.  
6  
7 (138) Mikami, K.; Takahashi, O.; Tabei, T.; Nakai, T. *Tetrahedron Lett.* **1986**, *27*, 4511-  
8  
9 4514.  
10  
11 (139) Marié, J.-C.; Xiong, Y.; Min, G. K.; Yeager, A. R.; Taniguchi, T.; Berova, N.; Schaus,  
12  
13 S. E.; Porco, J. A. *J. Org. Chem.* **2010**, *75*, 4584-4590.  
14  
15 (140) (a) Thornton, A. R.; Blakey, S. B. *J. Am. Chem. Soc.* **2008**, *130*, 5020-5021. (b) Mace,  
16  
17 N.; Thornton, A. R.; Blakey, S. B. *Angew. Chem. Int. Ed.* **2013**, *52*, 5836-5839.  
18  
19  
20  
21  
22  
23  
24  
25  
26  
27  
28  
29  
30  
31  
32  
33  
34  
35  
36  
37  
38  
39  
40  
41  
42  
43  
44  
45  
46  
47  
48  
49  
50  
51  
52  
53  
54  
55  
56  
57  
58  
59  
60